

CHAMPION

TRAILER AND PARTS CATALOG® #2023

www.championtrailers.com

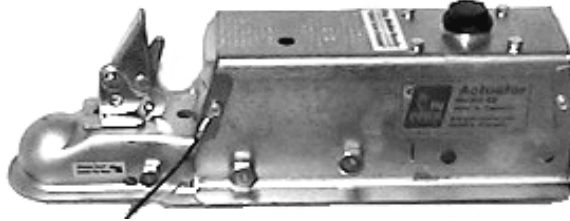

ALUMINUM/STAINLESS/GALV MATERIAL	42			SPINDLES / PARTS	8, 9
AXLE - GALVANIZED	2, 3, 7, 9	ELECTRIC BRAKES - GALVANIZED	35	SPRINGS - LEAF	10, 47
AXLE TUBING-GALVANIZED	42	FENDERS / BRACKETS	14, 15	SPRING BOLTS / BUSHINGS	10, 11
AXLE UBOLT KITS	10, 46	GREASE	9	SPRING HANGERS / KITS	11, 14, 46
BEARING KITS	5	GUIDE KITS	16	SPRING PADS	9
BEARING PROTECTORS	8	HITCH COMPONENTS	23	STAINLESS STEEL BRAKE TUBING	31
BOLTS - GALVANIZED	19	HUBS	4, 6,	TIE DOWNS	21
BOLTS - STAINLESS STEEL	16, 18	HUB DRUMS	5	TIRES / RIMS	12, 13
BOW STOPS - BOW ROLLERS	20	HUB MOUNT SPARE TIRE CARRIER	12	TONGUE TUBING - GALVANIZED	22, 42
BRAKE COUPLERS	36	HYDRAULIC BRAKE CLUSTERS AND PARTS	31, 33	TRANSOM SUPPORT	21
BUNK BRACKETS	15,	HYDRAULIC BRAKE COUPLERS	36	TRAILER - ALUMINUM	25
BUNK BOARDS	16	HYDRAULIC BRAKE COUPLER PARTS	32, 33	TRAILER - GALVANIZED	24
BUSHINGS	11	JACKS / PARTS	40, 41	TRAILER WIRING PLUGS	34
CARPET	16	LIGHTS / BRACKETS / ACCESSORIES	37 - 40	TURBO LUBE HUB	6, 7
CHAIN - GALVANIZED	21	LIQUID ROLLER	15	TURNBUCKLES	21
COLD GALV SPRAY	11, 15	LUG NUTS / BOLTS	4, 8, 18	UBOLTS - GALVANIZED	19
COUPLERS/ REPAIR KITS/ LOCKS	22	NEVER-SEEZ®	19	UBOLTS - STAINLESS STEEL	18
COUPLER BALLS	23	RECEIVER LOCKS / PINS	23	UNDER CARRIAGE SLIDERS	14
DISC BRAKE RETRO-FIT KIT	26	RIMS GALVANIZED	12	UTILITY TRAILER AXLES	46
DISC BRAKE COMPONENTS	27	ROLLERS, BRACKETS, AND PINS	15, 16, 17	UTILITY TRAILER PARTS KITS	44, 45
DRUM BRAKE RETRO-FIT KIT	30	SINGLE /TANDEM CONVERSION KIT	43	UTIL TRLR UNDER CARRIAGE KITS	46
DUST CAPS	6, 8	SAFETY CHAINS / CABLES	22	WINCHES	20
EQUALIZERS	11, 47	SCREWS - STAINLESS STEEL	16, 18	WINCH BASE	20
ELECTRIC BRAKES AND COMPONENTS	34, 35	SEALS	5, 9	WINCH POST	20
EYE BOLTS	21	SHACKLE LINKS	11	WIRING CABLE	34
EZ LOADER PARTS	47	SPARE TIRE CARRIERS	12	WINCH STRAP / CABLE	20

**TO PLACE AND ORDER CALL 1-800-229-6690
OR FAX YOUR ORDER TO 1-800-359-8169**

COPYRIGHT 2002

HOT DIP GALVANIZED AXLES FEATURING THE REVOLUTIONARY SPINDLE-LUBE® HUB LUBRICATION SYSTEM

WITH THIS AXLE YOU CAN CHANGE THE GREASE IN YOUR HUB **WITHOUT** REMOVING THE HUB OR WHEEL FROM THE TRAILER.

AS YOU PUMP NEW GREASE IN WITH YOUR GREASE GUN, THE OLD GREASE IS PURGED OUT, ALLOWING YOU TO TOTALLY REPLACE THE GREASE IN THE HUB IN LESS THAN 5 MINUTES PER HUB. AND ALL THIS IS DONE WITH THE TRAILER ON THE GROUND, WITHOUT REMOVING THE WHEEL OR HUB.

THE GREASE FITTING FOR THIS SYSTEM IS ON THE TIP OF THE SPINDLE. A GREASE PASSAGE IS BORED THROUGH THE CENTER OF THE SPINDLE AND IS THEN CROSS BORED AT THE REAR OF THE SPINDLE, ALLOWING GREASE TO BE PUMPED INTO THE HUB CAVITY AT A POINT BETWEEN THE SEAL AND THE REAR BEARING.

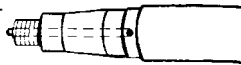

TO ACCESS THE GREASE FITTING, YOU REMOVE THE RUBBER PLUG IN THE DUST CAP. AS YOU PUMP NEW GREASE IN, THE OLD GREASE WILL BE PURGED OUT THROUGH THE HOLE IN THE DUST CAP AROUND THE TIP OF YOUR GREASE GUN.

HOW TO ORDER AN AXLE

(1) SELECT YOUR AXLE PART # AND MODEL # FROM THE CHARTS ON **PAGE 3**. BE SURE TO IDENTIFY **AXLE ON TOP** OR **AXLE UNDER** SPRINGS WHEN YOU SELECT YOUR MODEL #

(2) WE NOW NEED YOUR **AXLE TRACK** MEASUREMENT WHICH IS APPROXIMATELY THE CENTER OF ONE TIRE TO CENTER OF THE OTHER TIRE. THIS MEASUREMENT IS TAKEN FROM THE FACE OF ONE HUB TO THE FACE OF THE OTHER HUB.

DO NOT MEASURE FROM THE BACK OF THE HUB OR BRAKE FLANGE. THIS WOULD PROVIDE AN INCORRECT AXLE TRACK MEASUREMENT. MEASURE HUB FACE TO HUB FACE ONLY!!

(3) THE ONLY OTHER MEASUREMENT REQUIRED IS **SPRING CENTER**. SIMPLY STATED, THIS IS THE CENTER OF ONE SPRING TO THE CENTER OF THE OTHER SPRING. THIS IS AN IMPORTANT MEASUREMENT. (**QUICK TIP:** AN EASY WAY TO MEASURE SPRING CENTER IS TO HOOK A TAPE ON THE **OUTSIDE** OF ONE SPRING AND MEASURE TO THE **INSIDE** OF THE OTHER SPRING.) (**OUTSIDE TO INSIDE**). THIS WILL GIVE YOU AN ACCURATE SPRING CENTER MEASUREMENT.

HOW TO MEASURE AN AXLE

MEASUREMENT # 1 = AXLE TRACK
MEASUREMENT # 2 = SPRING CENTER

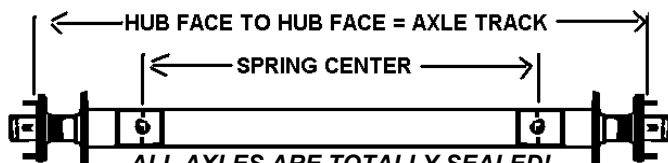

**ALL AXLES ARE TOTALLY SEALED!
NO WATER GETS INSIDE THE AXLE!**

EACH SPINDLE ON YOUR AXLE HAS IT'S OWN HUB PACKING TOOL BUILT INTO IT

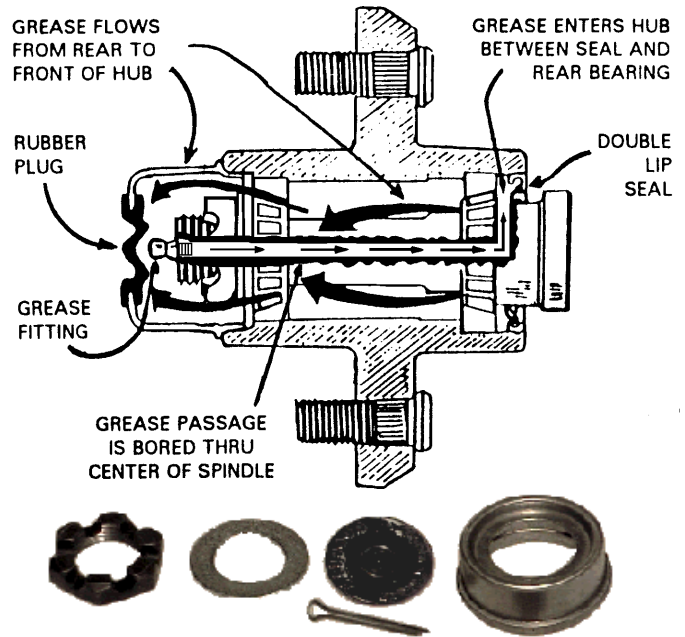

AXLES ARE AVAILABLE IN 3 CAPACITIES

(1) 2500# - ARE **STRAIGHT ONLY** AND ARE 2" X 2" HOT DIP GALVANIZED SQUARE AXLE STOCK WITH 1 1/16" X 1 1/16" SPINDLES, AND THEY USE BEARINGS **#44649 INNER AND #44649 OUTER**

(2) 3500# - ARE AVAILABLE IN **STRAIGHT OR DROP** WITH EITHER 2" X 2" SQUARE OR 2" X 3" RECTANGULAR HOT DIP GALVANIZED AXLE STOCK WITH 1 3/8" X 1 1/16" SPINDLES AND USE BEARINGS **# 68149 INNER AND #44649 OUTER**. 2" x 2" AXLES ARE ALSO AVAILABLE AS STRAIGHT OR SADDLE ("V") AXLE STOCK.

(3) 5200# - ARE **STRAIGHT OR DROP** AND ARE MANUFACTURED WITH 2" X 3" RECTANGULAR HOT DIP GALVANIZED AXLE STOCK AND HAVE 1 3/4" X 1 1/4" SPINDLES THAT USE BEARINGS **#25580 INNER AND #15123 OUTER**.

AXLE WARRANTY













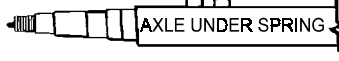

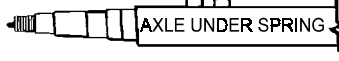

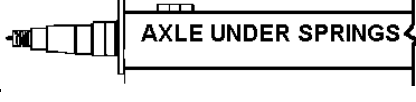
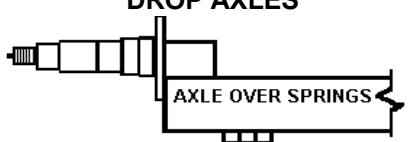
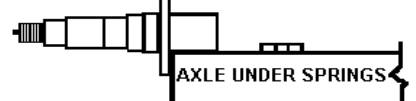

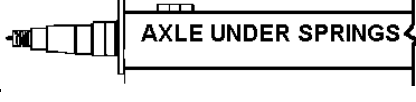
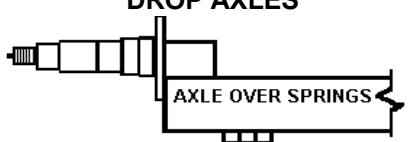
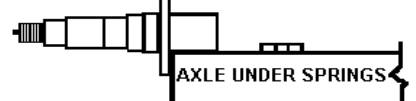

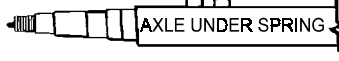

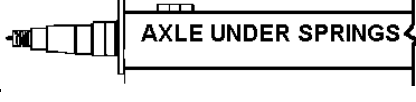
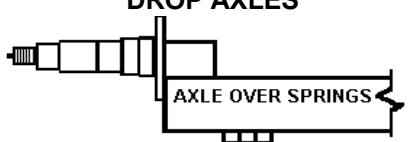
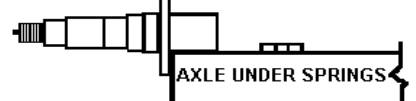

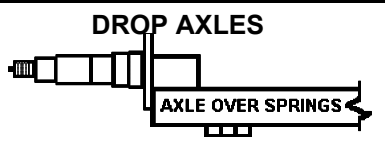
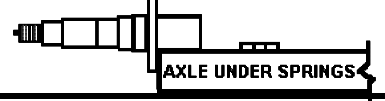

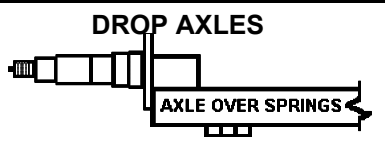
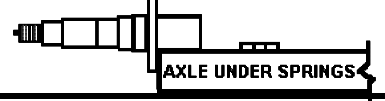

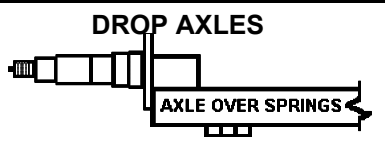
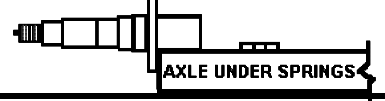





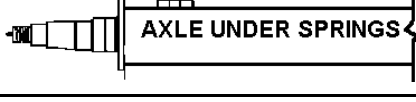
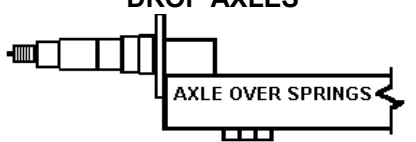
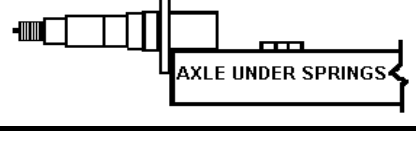

CHAMPION TRAILERS WARRANTS EACH AXLE AGAINST STRUCTURAL FAILURE (**CRACKED OR BROKEN WELDS**) FOR A PERIOD OF 2 (TWO) YEARS, **UNLESS THE AXLE IS OVERLOADED**. SPINDLE DAMAGE DUE TO FAILED BEARINGS IS NOT COVERED BY CHAMPION TRAILERS **UNLESS CHAMPION TRAILERS INSTALLS THE HUBS ON THE AXLE**. IF CHAMPION TRAILERS INSTALLS THE HUBS ON THE AXLE, THE HUBS AND BEARINGS ARE WARRANTED FOR ONE (1) YEAR AGAINST FAILURE.

**THERE IS A \$13.50 CHARGE FOR
HUB INSTALLATION PER AXLE**

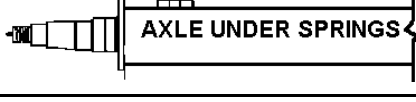
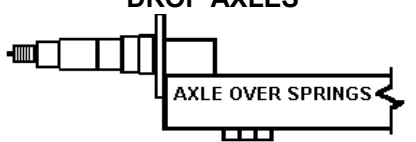
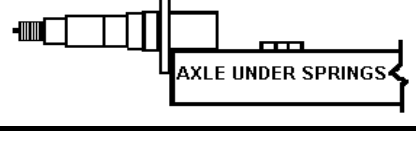
HOT DIP GALVANIZED SPINDLE-LUBE® AXLES

ALL SPINDLE-LUBE® AXLES ARE TOTALLY SEALED. THEY ARE MANUFACTURED TO CUSTOMER SPECIFICATIONS. **PLEASE BE PRECISE IN YOUR MEASUREMENTS!**

ORDER HUBS SEPARATELY. 1-800-229-6690

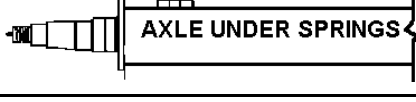
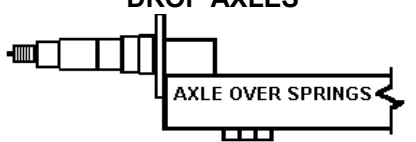
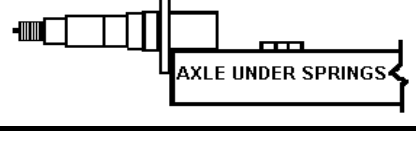
AXLES INCLUDE SPINDLE-LUBE® DUST CAP WITH RUBBER PLUG, COTTER PIN AND SPINDLE NUT/WASHER.		3500# - 2X3" RECTANGULAR AXLES 1 3/8 X 1 1/16" SPINDLES BEARINGS 68149 - INNER / 44649 - OUTER SEAL I.D. 1.71"																				
2500# - 2X2" SQUARE STRAIGHT AXLES 1 1/16" STRAIGHT SPINDLES BEARINGS 44649 - INNER / 44649 - OUTER SEAL I.D. 1.25"	<table border="1" style="width: 100%; border-collapse: collapse;"> <thead> <tr> <th style="width: 10%;">PART #</th> <th style="width: 70%;">PRICE</th> </tr> </thead> <tbody> <tr> <td>ATS25 MO # 1</td> <td style="text-align: center;">  \$107.95 49# </td> </tr> <tr> <td>ABS25 MO # 2</td> <td style="text-align: center;">  \$107.95 49# </td> </tr> </tbody> </table>	PART #	PRICE	ATS25 MO # 1	 \$107.95 49#	ABS25 MO # 2	 \$107.95 49#	<table border="1" style="width: 100%; border-collapse: collapse;"> <thead> <tr> <th style="width: 10%;">PART #</th> <th style="width: 70%;">PRICE</th> </tr> </thead> <tbody> <tr> <td>XATS35 MO # 29</td> <td style="text-align: center;">  \$119.95 57# </td> </tr> <tr> <td>XABS35 MO # 30</td> <td style="text-align: center;">  \$119.95 57# </td> </tr> <tr> <td>XATD35 MO # 23</td> <td style="text-align: center;"> DROP AXLES  \$126.95 57# </td> </tr> <tr> <td>XABD35 MO # 24</td> <td style="text-align: center;">  \$126.95 57# </td> </tr> </tbody> </table>	PART #	PRICE	XATS35 MO # 29	 \$119.95 57#	XABS35 MO # 30	 \$119.95 57#	XATD35 MO # 23	DROP AXLES  \$126.95 57#	XABD35 MO # 24	 \$126.95 57#				
PART #	PRICE																					
ATS25 MO # 1	 \$107.95 49#																					
ABS25 MO # 2	 \$107.95 49#																					
PART #	PRICE																					
XATS35 MO # 29	 \$119.95 57#																					
XABS35 MO # 30	 \$119.95 57#																					
XATD35 MO # 23	DROP AXLES  \$126.95 57#																					
XABD35 MO # 24	 \$126.95 57#																					
3500# - 2X2" HEAVY SQUARE AXLES 1 3/8 X 1 1/16" SPINDLES BEARINGS 68149 - INNER / 44649 - OUTER SEAL I.D. 1.71"	<table border="1" style="width: 100%; border-collapse: collapse;"> <thead> <tr> <th style="width: 10%;">PART #</th> <th style="width: 70%;">PRICE</th> </tr> </thead> <tbody> <tr> <td>ATSF35 MO # 17</td> <td style="text-align: center;">  \$117.95 53# </td> </tr> <tr> <td>ABSF35 MO # 18</td> <td style="text-align: center;">  \$117.95 53# </td> </tr> <tr> <td>ATDF35 MO # 7</td> <td style="text-align: center;"> DROP AXLES  \$119.95 53# </td> </tr> <tr> <td>ABDF35 MO # 8</td> <td style="text-align: center;">  \$119.95 53# </td> </tr> </tbody> </table>	PART #	PRICE	ATSF35 MO # 17	 \$117.95 53#	ABSF35 MO # 18	 \$117.95 53#	ATDF35 MO # 7	DROP AXLES  \$119.95 53#	ABDF35 MO # 8	 \$119.95 53#	5200# 1/4 X 2 X 3" RECTANGULAR AXLES 1 3/4" X 1 1/4" SPINDLES BEARINGS 25580 - INNER AND 15123 - OUTER SEAL I.D. 2.25"										
PART #	PRICE																					
ATSF35 MO # 17	 \$117.95 53#																					
ABSF35 MO # 18	 \$117.95 53#																					
ATDF35 MO # 7	DROP AXLES  \$119.95 53#																					
ABDF35 MO # 8	 \$119.95 53#																					
3500# 2 X 2" HEAVY SQUARE SADDLE ("V") AXLES 1 3/8 X 1 1/16" SPINDLES BEARINGS 68149 - INNER / 44649 OUTER SEAL I.D. 1.71"	<table border="1" style="width: 100%; border-collapse: collapse;"> <thead> <tr> <th style="width: 10%;">PART #</th> <th style="width: 70%;">PRICE</th> </tr> </thead> <tbody> <tr> <td>SATS35 OVER SPRING STRAIGHT MO # 40</td> <td style="text-align: center;">  \$137.95 53# </td> </tr> <tr> <td>SABS35 UNDER SPRING STRAIGHT MO # 41</td> <td style="text-align: center;">  \$137.95 53# </td> </tr> <tr> <td>SATD35 OVER SPRING DROP MO # 42</td> <td style="text-align: center;"> DROP SADDLE (SPECIFY AXLE OVER OR UNDER SPRINGS)  \$139.95 53# </td> </tr> <tr> <td>SABD35 UNDER SPRING DROP MO # 43</td> <td style="text-align: center;">  \$139.95 53# </td> </tr> </tbody> </table>	PART #	PRICE	SATS35 OVER SPRING STRAIGHT MO # 40	 \$137.95 53#	SABS35 UNDER SPRING STRAIGHT MO # 41	 \$137.95 53#	SATD35 OVER SPRING DROP MO # 42	DROP SADDLE (SPECIFY AXLE OVER OR UNDER SPRINGS)  \$139.95 53#	SABD35 UNDER SPRING DROP MO # 43	 \$139.95 53#	<table border="1" style="width: 100%; border-collapse: collapse;"> <thead> <tr> <th style="width: 10%;">PART #</th> <th style="width: 70%;">PRICE</th> </tr> </thead> <tbody> <tr> <td>AT52 MO # 35</td> <td style="text-align: center;">  \$179.00 65# </td> </tr> <tr> <td>AB52 MO # 36</td> <td style="text-align: center;">  \$179.00 65# </td> </tr> <tr> <td>ATD52 MO # 37</td> <td style="text-align: center;"> DROP AXLES  \$195.00 65# </td> </tr> <tr> <td>ABD52 MO # 38</td> <td style="text-align: center;">  \$195.00 65# </td> </tr> </tbody> </table>	PART #	PRICE	AT52 MO # 35	 \$179.00 65#	AB52 MO # 36	 \$179.00 65#	ATD52 MO # 37	DROP AXLES  \$195.00 65#	ABD52 MO # 38	 \$195.00 65#
PART #	PRICE																					
SATS35 OVER SPRING STRAIGHT MO # 40	 \$137.95 53#																					
SABS35 UNDER SPRING STRAIGHT MO # 41	 \$137.95 53#																					
SATD35 OVER SPRING DROP MO # 42	DROP SADDLE (SPECIFY AXLE OVER OR UNDER SPRINGS)  \$139.95 53#																					
SABD35 UNDER SPRING DROP MO # 43	 \$139.95 53#																					
PART #	PRICE																					
AT52 MO # 35	 \$179.00 65#																					
AB52 MO # 36	 \$179.00 65#																					
ATD52 MO # 37	DROP AXLES  \$195.00 65#																					
ABD52 MO # 38	 \$195.00 65#																					
<p style="font-size: 1.5em; font-weight: bold;">★★ NOTICE ★★</p> <p style="text-align: center;">IF YOU DO NOT PURCHASE NEW HUBS FROM CHAMPION TRAILERS WITH YOUR NEW AXLE, GREASE MAY LEAK PAST THE SEAL OF YOUR EXISTING HUB. YOUR HUB MAY BE FRACTIONALLY SHORTER THAN OUR HUBS. GREASE LEAKING PAST THE SEAL OF YOUR OLD HUB IS NOT A WARRANTY CONDITION</p>																						

STAINLESS STEEL LUG NUTS 13/16" OD X 1/2" -20

PURCHASE Never-seez® on Page 19

PART #	DESCRIPTION	WT	PRICE
6065	SS STANDARD LUG NUT EA	.25#	\$1.69
6066	SS STANDARD BAG OF 10	2.5#	\$15.00
1461	SS DEEP SOCKET LUG NUT EA	.4#	\$2.89
1462	SS DEEP SOCKET LUG NUT BAG OF 10	4#	\$24.95

ALWAYS USE AN ANTI-SEIZE AGENT ON THREADS



UPGRADE YOUR "NEW" HUB TO A SPINDLE-LUBE® HUB AND HAVE IT PACKED WITH GREASE.

NO BEARING PROTECTORS NECESSARY. WORKS ON THE SAME PRINCIPAL AS THE SPINDLE-LUBE® AXLES MANUFACTURED BY CHAMPION TRAILERS. GREASE FITTING IS INSTALLED RIGHT IN FRONT OF THE REAR SEAL SO THAT THE GREASE FLOWS FORWARD AND ALL OF THE OLD GREASE IS PURGED OUT THROUGH THE FRONT OF THE HUB AS IT IS FILLED WITH NEW GREASE.

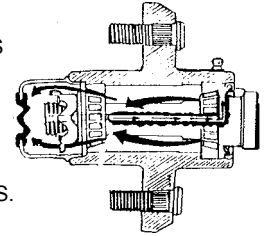

*UPGRADE INCLUDES A SPINDLE-LUBE® DUST CAP AND RUBBER PLUG.
*UPGRADE ALSO AVAILABLE FOR SS DISC BRAKES. (NOT AVAILABLE FOR DRUM BRAKES.)

PART # 1456 UPGRADE PRICE PER HUB \$11.00

HOT DIP GALVANIZED IDLER HUBS

INCLUDES BEARINGS, RACES, DOUBLE LIP SEAL, ZINC LUG NUTS AND DUST CAP

PART #	SPINDLE SIZE	HUB LENGTH	BOLT PATTERN	BEARINGS INNER/OUTER	SEAL ID	WT	PRICE
1451	1"	4"	4 ON 4	44643 / 44643	1.25"	8#	\$24.95
1452	1"	4"	5 ON 4.5	44643 / 44643	1.25"	8#	\$24.99
1453	1 1/16"	4"	4 ON 4	44649 / 44649	1.25"	8#	\$24.95
1454	1 1/16"	4"	5 ON 4.5	44649 / 44649	1.25"	8#	\$24.99
1463	1 1/16"	4"	4 ON 4	44649 / 44649	1.50"	8#	\$24.95
1464	1 1/16"	4"	5 ON 4.5	44649 / 44649	1.50"	8#	\$24.99
1455	1 3/8 X 1 1/16"	4"	5 ON 4.5	68149 / 44649	1.72"	12#	\$28.95
1465	1 3/8 X 1 1/16"	4"	5 ON 4.5	68149 / 44649	1.69" (EZ)	12#	\$29.95



WILL NOT FIT IN 8" RIMS

PAINTED IDLER HUBS

INCLUDES BEARINGS, RACES, DOUBLE LIP SEAL, ZINC LUG NUTS AND DUST CAP

PART #	SPINDLE SIZE	HUB LENGTH	BOLT PATTERN	BEARINGS INNER/OUTER	SEAL ID	WT	PRICE EACH
0202	3/4"	4"	5 ON 4.5	11949 / 11949	111784	7#	\$29.95
0201	1"	4.25"	4 ON 4	44643 / 44643	1.25"	8#	\$20.95
0203	1"	4.25"	5 ON 4.5	44643 / 44643	1.25"	8#	\$20.95
0248	1 1/16"	4.25"	4 ON 4	44649 / 44649	1.25"	8#	\$20.95
0249	1 1/16"	4.25"	5 ON 4.5	44649 / 44649	1.25"	8#	\$20.95
4116	1 1/16" SHORT	3.25"	5 ON 4.5	44649 / 44649	1.25"	8#	\$38.99
4117	1 1/16"	4.25"	4 ON 4	44649 / 44649	1.50"	8#	\$20.95
4118	1 1/16"	4.25"	5 ON 4.5	44649 / 44649	1.50"	8#	\$20.95
0207	1 1/4"	3.75"	5 ON 4.5	67048 / 67048	1.50"	8#	\$39.95
0208	1 1/4"	3.75"	5 ON 4.5	67048 / 67048	1.68"	8#	\$39.95
0252	1 1/4 X 3/4"	4 1/8"	5 ON 4.5	67048 / 11949	1.50"	12#	\$31.95
4119	1 1/4 X 3/4"	4 1/8"	5 ON 4.5	67048 / 11949	1.68"	12#	\$31.95
0204	1 3/8 X 1 1/16"	4.25"	5 ON 4.5	68149 / 44649	1.72"	12#	\$23.95
4120	1 3/8 X 1 1/16"	4.25"	5 ON 4.5	68149 / 44649	1.69"	12#	\$24.95
3045	1 3/8 X 1 1/16"	4.25"	5 ON 5" CHVY	68149 / 44649	1.72"	12#	\$28.95
6062	1 3/8 X 1 1/16"	4.25"	5 ON 4.75"	68149 / 44649	1.72"	12#	\$29.95
6063	1 3/8 X 1 1/16"	4.25"	5 ON 5.5"	68149 / 44649	1.72"	12#	\$29.95
6064	1 3/8 X 1 1/16"	4.25"	6 ON 5.5"	68149 / 44649	1.72"	12#	\$30.95
0205	1 3/4 X 1 1/4"	4.50"	6 LUG	25580 / 15123	2.125"	17#	\$41.99
4121	1 3/4 X 1 1/4"	4.50"	6 LUG	25580 / 15123	2.250"	17#	\$41.99
0206	1 3/4 X 1 1/4"	4.50"	8 LUG	25580 / 14125A	2.125"	21#	\$49.99
4122	1 3/4 X 1 1/4"	4.50"	8 LUG	25580 / 14125A	2.250"	21#	\$49.99

ALWAYS PRE-LOAD BEARINGS IN NEW HUBS BEFORE USING

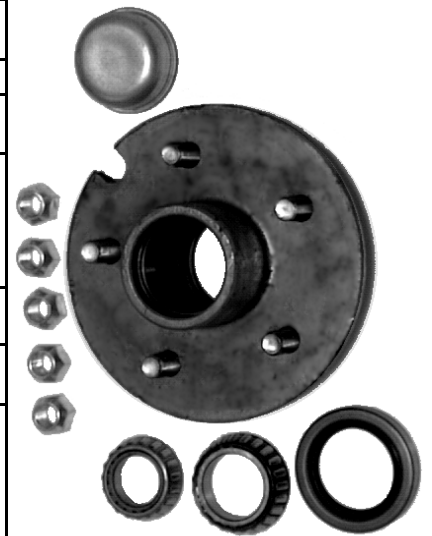

HOW TO MEASURE THE BOLT PATTERN FOR A 5 LUG HUB

4.5" BOLT CIRCLE - 545 STANDARD 5 LUG BOLT PATTERN FOR MOST BOAT TRAILER HUBS & RIMS.
4.75" BOLT CIRCLE - 5475 RIMS MAY BE HARD TO FIND.
5" BOLT CIRCLE - 550 - 5 LUG BOLT PATTERN. WIDELY AVAILABLE AND USED MAINLY ON UTILITY TRAILERS.
5.5" BOLT CIRCLE - 555 COMMONLY REFERRED TO AS THE "BIG" FORD PATTERN. RIM SIZE FOUND ON MANY RECENT YEAR FORD TRUCKS.

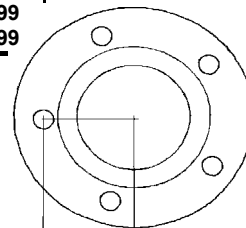

MEASURE FROM CENTER OF HUB TO CENTER OF ONE STUD THEN MULTIPLY BY TWO.

- 2 1/4" 5 ON 4.5" (545)
- 2 3/8" 5 ON 4.75" (5475)
- 2 1/2" 5 ON 5" (550)
- 2 3/4" 5 ON 5.5" (555)

ALL OF THE 5 LUG HUBS LISTED ABOVE ARE AVAILABLE TO FIT AN 1 3/8 X 1 1/16" SPINDLE SIZE (68149 INNER BEARING / 44649 OUTER BEARING).

THE RESULT IS YOUR BOLT CIRCLE

PAINTED BRAKE HUB DRUMS INCLUDES BEARINGS, RACES, DOUBLE-LIP SEALS, ZINC LUG NUTS AND DUST CAP

PART #	BRAKE SIZE	SPINDLE	BEARINGS INNER / OUTER	SEAL ID	BOLT PATTERN	WT	PRICE EACH
0571 0572	7" X 1 3/4" 7" X 1 3/4"	1 1/16" 1 1/16"	44649 / 44649 44649 / 44649	1.25" 1.25"	4 ON 4 5 ON 4.5" FORD	22# 22#	\$49.95 \$49.95
3048 3049	8 1/2" X 2 1/4" 8 1/2" X 2 1/4"	1 3/8 X 1 1/16" 1 3/8 X 1 1/16"	68149 / 44649 68149 / 44649	1.72" 1.72"	5 ON 4.5" FORD 5 ON 5.5"	28# 28#	\$69.95 \$69.95
0504 4140 0509 3050 4141 3051 3052	10" HYD ONLY 10" HYD ONLY 10" ELEC ONLY 10" ELEC/ HYD 10" ELEC/ HYD 10" ELEC/ HYD 10" ELEC/ HYD	1 3/8 X 1 1/16" 1 3/8 X 1 1/16" 1 3/8 X 1 1/16" 1 3/8 X 1 1/16" 1 3/8 X 1 1/16" 1 3/8 X 1 1/16" 1 3/8 X 1 1/16"	68149 / 44649 68149 / 44649 68149 / 44649 68149 / 44649 68149 / 44649 68149 / 44649 68149 / 44649	1.72" 1.69" (EZ) 1.72" 1.72" 1.72" 1.72" 1.72"	5 ON 4.5" FORD 5 ON 4.5" FORD 5 ON 4.5" 5 ON 5" CHEVY 6 ON 5.5" 5 ON 5.5" 5 ON 4.75"	32# 32# 35# 35# 36# 35# 35#	\$44.95 \$45.95 \$49.95 \$46.95 \$49.95 \$49.95 \$49.95
6009	10" ELEC/HYD	1 1/4 X 3/4"	67048 / 11949	1.68	5 ON 4.5" FORD	35#	\$59.95
0505 4142 0506 4144	12" ELEC/HYD 12" ELEC/HYD 12" ELEC/HYD 12" ELEC/HYD	1 3/4 X 1 1/4" 1 3/4 X 1 1/4" 1 3/4 X 1 1/4" 1 3/4 X 1 1/4"	25580 / 15123 25580 / 15123 25580 / 14125A 25580 / 14125A	2.125" 2.250" 2.125" 2.250"	6 LUG ON 5.5" 6 LUG ON 5.5" 8 LUG 8 LUG	45# 45# 50# 50#	\$59.95 \$59.95 \$69.95 \$69.95

**BEARING AND RACE KITS** INCLUDE BEARINGS, RACES, DOUBLE LIP SEAL, AND COTTER PIN

PART #	SPINDLE SIZE	INNER BRG	OUTER BRG	SEAL OD	SEAL ID	TRANSCOM SEAL #	WT	KIT PRICE
0233	3/4"	11949	11949	1.78"	1.11"	111784UH	1#	\$10.95
0213	1"	44643	44643	1.98"	1.25"	125192	1.5#	\$9.99
0214 3053	1 1/16" 1 1/16"	44649 44649	44649 44649	1.98" 1.98"	1.25" 1.50"	125192 15192	1.5# 1.5#	\$9.99 \$9.99
0215	1 1/4"	67048	67048	2.33"	1.50"	15234	1.5#	\$12.95
0216 4007	1 1/4 X 3/4" 1 1/4 X 3/4"	67048 67048	11949 11949	2.33" 2.33"	1.50" 1.68"	15234 168233	1.5# 1.5#	\$13.95 \$13.95
0217 4137 4138	1 3/8 X 1 1/6" 1 3/8 X 1 1/6" 1 3/8 X 1 1/6"	68149 68149 68149	44649 44649 44649	2.56" 2.56" 2.33"	1.72" 1.69" 1.68"	17255 169255 EZ 168233 TRLRT	1.5# 1.5# 1.5#	\$10.95 \$13.95 \$13.95
0218 3056 3054 3057 4139 0255 3058	1 3/4 X 1 1/4" 1 3/4 X 1 1/4" 1 3/4 X 1 1/4" 1 3/4 X 1 1/4" 1 3/4 X 1 1/4" 1 3/4 X 1 1/4" 1 3/4 X 1 1/4"	25580 25580 25580 25580 25580 25580 25580	15123 15123 67048 67048 67048 14125A 14125A	3.37" 3.37" 3.37" 3.37" 3.250" 3.37" 3.37"	2.250" 2.125" 2.250" 2.125" 2.125" 2.250" 2.125"	22333 21333 22333 21333 21325 22333 21333	3# 3# 3# 3# 3# 3.5# 3.5#	\$21.95 \$21.95 \$21.95 \$21.95 \$22.95 \$26.95 \$26.95



ALL BEARING KITS EXCEPT # 0233 COME WITH DOUBLE LIP SEALS

KIT # 4139 FITS EZLOAD® AND TRAILRITE® 6 LUG HUBS

PART #	INNER BRG #	SEAL O.D.	SEAL I.D.	TRANSCOM #	NAT'L #	NOK #	WT	PRICE EACH
3065	11949	1.785"	1.125"	11784UHY			.3#	\$2.95
0228 0229	44643 / 44649 44643 / 44649	1.98" 1.98"	1.25" 1.50"	125192 15192	471750	AD1836E AD2267E	.3# .3#	\$2.20 \$2.50
0253 4008	67048 67048 / 68149	2.33" 2.33"	1.50" 1.68"	15234 168233	473317	AD2527E	.3# .3#	\$2.85 \$2.95
0230 3068	68149 68149	2.56" 2.56"	1.72" 1.69"	17255 169255	473336 470460	AD2548E UD0135E	.3# .3#	\$2.20 \$2.95
0231 3066 3067	25580 25580 25580	3.37" 3.37" 3.25"	2.125" 2.250" 2.125"	21333 22333 21325	470972	AD7131E	.4# .4# .4#	\$3.95 \$3.95 \$4.95

**DOUBLE
LIP
SEALS**



SEAL # 3068 FITS EZ LOAD® 5 LUG 3500# HUBS

SEAL # 3067 FITS EZ LOAD® AND TRAILRITE® 6 LUG HUBS

CALL TOLL FREE TO PLACE AN ORDER 1-800-229-6690 OR FAX 1-800-359-8169

www.championtrailers.com

TURBO-LUBE® OIL FILLED HUBS

NOW AVAILABLE FROM TIE DOWN ENGINEERING®



HUBS THAT GIVE YOU THE SAME OIL-FILLED HUB LUBRICATION SYSTEM THAT HAS BEEN AVAILABLE FOR DECADES FOR 18 WHEELER TRAILERS.

HEAVY DUTY CLEAR LEXAN® THREADED DUST CAP ALLOWS VISUAL OIL LEVEL INSPECTION

THREADED FILLER PLUG ALLOWS EASY ADDITION OF OIL TO HUBS ON ROAD TRIPS, OR FOR STANDARD HUB MAINTAINENCE

ALL HUBS OR HUB DRUMS COME WITH BEARINGS, RACES, SEAL, LUG NUTS, OIL FILL PLUG AND THREADED CLEAR LEXAN® DUSTCAP

NOTE: ALL 5 LUG HUBS OR HUB DRUMS ARE 5 LUG ON 4.5" BOLT PATTERN (545) NO OTHER 5 LUG BOLT PATTERNS ARE AVAILABLE!

PART #	INNER BRG	OUTER BRG	SEAL ID	DESCRIPTION	WT	PRICE
0189	44643	44643	1.25"	1" - 4 STUD PAINTED	8#	\$33.95
0190	44643	44643	1.25"	1" - 5 STUD PAINTED (545 BOLT PATTERN)	8#	\$33.95
0191	44649	44649	1.25"	1 1/16" - 4 STUD PAINTED	8#	\$33.95
0192	44649	44649	1.50"	1 1/16" - 4 STUD PAINTED	8#	\$33.95
0193	44649	44649	1.25"	1 1/16"-5 STUD PAINTED (545 BOLT PATTERN)	8#	\$33.95
0194	44649	44649	1.50"	1 1/16"-5 STUD PAINTED (545 BOLT PATTERN)	8#	\$33.95
0195	68149	44649	1.72"	1 3/8" X 1 1/16" 5 STUD PAINTED (545 BOLT PATTERN)	12#	\$38.95
0196	68149	44649	1.68"	1 3/8" X 1 1/16" 5 STUD PAINTED (545 BOLT PATTERN FITS EZLOADER® OR TRAILRITE® TRAILERS)	12#	\$39.95
0197	68149	44649	1.72"	1 3/8" X 1 1/16" 5 STUD GALVANIZED (545 BOLT PATTERN)	12#	\$41.95
0198	68149	44649	1.68"	1 3/8" X 1 1/16" 5 STUD GALVANIZED (545 BOLT PATTERN) FITS EZLOADER® OR TRAILRITE® TRAILERS	12#	\$42.95
0199	68149	44649	1.72"	10" 545 PAINTED HUB DRUM 1 3/8 X 1 1/16"	32#	\$59.95
0200	68149	44649	1.68"	10" 545 PAINTED HUB DRUM 1 3/8 X 1 1/16" FITS EZLOADER® OR TRAILRITE® TRAILERS	32#	\$60.95
0209	25580	15123	2.25"	6 LUG PAINTED IDLER HUB 1 3/4 X 1 1/4"	18#	\$58.95
0210	25580	15123	2.125"	6 LUG PAINTED IDLER HUB 1 3/4 X 1 1/4"	18#	\$58.95

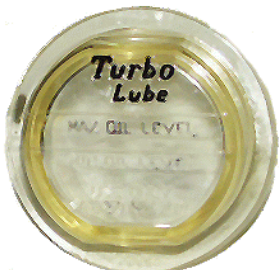

PART #	DESCRIPTION	WT	PRICE EA
48355	LEXAN® TURBO LUBE® DUST CAP TO FIT ALL 1.98 HUB BORE HUBS	.6#	\$6.95 EA
48357	LEXAN® TURBO LUBE® DUST CAP TO FIT ALL 6 LUG HUBS	.8#	\$7.95 EA

ORDERING TURBO LUBE® HUBS

BEFORE ORDERING TURBO LUBE® HUBS:

BE SURE TO CONFIRM THE **BEARING NUMBERS** IN YOUR EXISTING HUB

AND CONFIRM THE SPINDLE SEAL SEAT DIAMETER.

THAT IS THE PORTION OF THE SPINDLE THAT THE SEAL RIDES ON!!!!

IF NECESSARY, USE A DIAL CALIPER TO ESTABLISH THE DIAMETER OF THE SEAL SEAT.

FOR SUCCESSFUL OPERATION OF THE TURBO LUBE® HUB, IT IS ESSENTIAL THAT THE **CORRECT SEAL I.D.** BE ESTABLISHED TO MATCH THE SPINDLE SEAL SEAT DIAMETER ON YOUR AXLE, AND THAT THE SPINDLE SEAL SEAT BE VERY **SMOOTH**. IF YOUR SEAL SEAT IS ROUGH OR GROOVED, IT SHOULD BE DRESSED DOWN WITH FINE GRIT EMERY CLOTH. IF THE SEAL SEAT IS LEFT IN A ROUGH CONDITION, OIL MAY LEAK PAST THE SEAL. **THIS IS NOT A WARRANTY CONDITION!!!**

NOTE: TURBO LUBE® HUBS ARE NOT COMPATIBLE WITH SPINDO-SEAL® OR OTHER BRANDS OF LOOSE FITTING SEAL SEAT REPAIR SLEEVES.

SMALL AMOUNTS OF OIL MAY LEAK PAST THE SEAL DURING NORMAL HIGHWAY OPERATIONS. THIS CAN BE EXPECTED, AND WILL NOT ADVERSELY AFFECT THE LUBRICATION OF THE BEARINGS, **PROVIDING THAT OIL IS VISIBLE IN THE DUST CAP**. THIS IS WHY IT IS RECOMMENDED THAT YOU PERIODICALLY INSPECT THE CLEAR LEXAN® DUSTCAP FOR OIL LEVEL

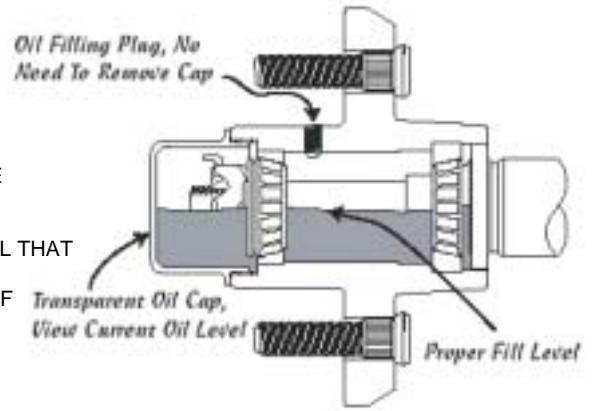

TURBO LUBE® HUB INSTALLATION

REMOVE EXISTING HUB FROM AXLE

CLEAN AND INSPECT SPINDLE AND SPINDLE SEAL SEAT FOR DAMAGE, CORROSION OR WEAR.

IF NECESSARY, REPAIR SPINDLE OR REPLACE THE AXLE.

(SEE PAGE 3 FOR AXLES) **WARNING - TURBO LUBE® HUBS WILL NOT WORK SUCCESSFULLY WITH ROUGH OR DAMAGED SPINDLE SEAL SEATS**

IF YOUR SPINDLE HAS A **PRESSED ON WEAR SLEEVE**, YOU WILL NEED TO SEAL THE INNER LIP OF THE WEAR SLEEVE WITH A SILICONE SEALANT OR PERMATEX® FORM-A-GASKET®. ALLOW SEALANT TO TOTALLY CURE BEFORE INSTALLING HUB. NOTE: AXLES WITH **SPINDLE LUBE®, ACCULUBE®, POSILUBE®** OR OTHER BRANDS OF REVERSE HUB LUBE SPINDLES WILL NORMALLY WORK VERY COMPATIBLY WITH TURBO LUBE® HUBS WITHOUT ANY MODIFICATION EXCEPT SEALING THE INNER EDGE OF THE WEAR SLEEVE. FOR RELIABLE® SURELUBE® SPINDLES, THE GREASE OUTFLOW HOLE MUST BE PLUGGED WITH SILICON SEALANT.

COAT THE OUTER EDGE OF THE SEAL WITH A THIN LAYER OF SILICONE SEALANT OR PERMATEX FORM-A-GASKET® (NOT INCLUDED). NOW INSTALL THE INNER BEARING AND SEAL INTO THE HUB. DRIVE THE SEAL INTO THE REAR HUB BORE UNTIL IT IS EVEN WITH THE BACK EDGE OF THE HUB, **(NO FUTHER!!)**

ALLOW SEALANT TO TOTALLY CURE BEFORE ADDING OIL TO HUB.

INSTALL THE HUB ONTO THE SPINDLE WITH SPINDLE NUT AND SPINDLE WASHER. TIGHTEN THE SPINDLE NUT UNTIL SNUG AND THEN TIGHTEN DOWN ANOTHER 1/4 TURN (APPROXIMATELY 10FT#). NOW TURN THE HUB 10 OR 12 REVOLUTIONS. THIS WILL FULLY SEAT THE RACES. NEXT, BACK OFF THE SPINDLE NUT UNTIL THE HUB IS LOOSE, AND THEN RE-SNUG THE SPINDLE NUT. AT THIS TIME THERE SHOULD BE NO PLAY (SLACK) IN THE BEARINGS.

TURBO LUBE® HUBS SHOULD HAVE 0 -.010" OF BEARING PLAY IN THE SPINDLE NUT SET POINT. FOR OPTIMUM PERFORMANCE, THERE SHOULD BE 0" BEARING PLAY (SLACK).

USE TEFLON TAPE® IN THE THREADS OF THE CLEAR PLASTIC DUST CAP AND SCREW INTO THE HUB UNTIL SNUG. APPROXIMATELY 15 INCH# OF TORQUE. DO NOT OVER TIGHTEN!!

FILL THE HUB WITH 80 - 90W GEAR OIL, UNTIL THE SETTLED OIL LEVEL IS ABOUT 1/2 WAY UP ON THE CLEAR PLASTIC DUST CAP.

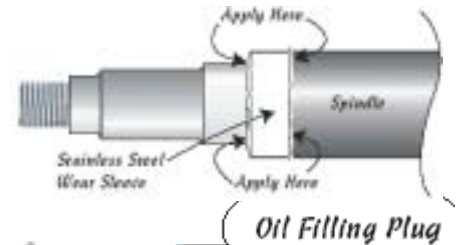

TURBO LUBE® AXLES WITH OIL FILLED IDLER HUBS INSTALLED				
AXLES DO NOT HAVE SPRING PADS. YOU MUST DRILL HOLES FOR SPRING PAD LOCATION ON AXLE				
PART #	DESCRIPTION	AXLE TRACK	WT	PRICE PER AXLE
0244	3500# - 1/4" X 2 X 2 AXLE FOR 60" WIDE FRAME	72"	66#	\$189.95
0245	3500# - 1/4" X 2 X 2 AXLE FOR 72" WIDE FRAME	83.88"	69#	\$192.95
0246	3500# - 1/4" X 2 X 2 AXLE FOR 80" WIDE FRAME	92"	72#	\$195.95



PART #	HUB BORE	OUTER BRG #	WT	PRICE EACH
0225	1.98	44649	.4#	\$3.50
3078	2.44	15123	.4#	\$4.95
4166	2.72	14125A	.5#	\$5.95
3079	REPLACEMENT RUBBER PLUG		.1#	\$1.44



GENUINE STAINLESS STEEL BEARING BUDDY®

STAINLESS BEARING PROTECTORS CLAM SHELL PACKED



[PER PAIR]

PART #	MODEL#	HUB BORE	WT	PRICE
41204	1781SS	1.78"	1.5#	\$13.99
42204	1980SS	1.98"	1.5#	\$13.99
43104	2328SS	2.33"	2#	\$16.99
42444	2441SS*	2.44"	2#	\$21.95
42714	2717SS*	2.72"	2.5#	\$29.95

*2441SS & 2717SS ARE ONLY AVAILABLE BOXED

PART #	HUB BORE	OUTER BRG #	WT	PRICE EACH
0254	1.78	11949	.3#	\$1.95
0222	1.98	44643 44649	.3#	\$1.29
6123	2.33	67048	.4#	\$2.49
0223	2.44	15123	.4#	\$2.79
0224	2.72	14125A	.5#	\$3.99



ZINC LUGNUT 1/2-20 X 13/16" OD

PART # 0221
WT .25#
PRICE EA \$.59



1/2-20X13/16" HEX HEAD LUGBOLT

PART # 0220
WT .3#
PRICE EA \$.89



1/2-20 DOUBLE ENDED STUD WITH HEX LUGNUT

CHANGES BOLT HOLE HUB TO STUD HUB



PART #	DOUBLE ENDED STUD W/LUGNUT	WT	PRICE
4162	D/E STUD W/ ZINC LUGNUT	.3#	\$1.69
6067	D/E STUD W/ STAINLESS LUG NUT (SEE SS NOTE ABOVE)	.3#	\$2.89

FULTON® BEARING PROTECTORS

SOLD 1 PAIR PER PACKAGE
REPLACES DUSTCAP IN WHEEL HUB
AUTOMATICALLY LUBRICATES AND
PROLONGS BEARING LIFE
FITTED (BRA) COVERS SOLD SEPARATELY
(PER PAIR)

PART #	HUB BORE	OUTER BRG #	WT	PRICE PER PR
3069	1.78	11949	1.5#	\$11.60
3070	1.98	44649 44643	1.5#	\$11.60
3071	2.32	67048	2.5#	\$15.95
4163	2.44	15123	2.5#	\$19.95



BEARING PROTECTOR BRAS

PART #	DESCRIPTION	WT	PRICE PER PR
0265	1.78 BRA	.4#	\$2.95
0211	1.98 BRA	.4#	\$2.95
0212	2.32/2.44 BRA	.4#	\$2.95

BEARING BUDDY BRAS®

[PER PAIR]



PART #	MODEL #	BRG BUDDY MODEL #	WT	PRICE
70017	17B	1781SS	1#	\$2.95
70019	19B	1980SS	1#	\$2.95
70023	23B	2328SS 2441SS 2717SS	1#	\$2.95

SURE LUBE® GREASABLE DUST CAPS



FITS EZ LOADER® TRAILERS

PART #	DESCRIPTION	DIA	WT	PRICE
R1980	STEEL - ZINC PLATED SURE LUBE®	1.98"	.30#	\$2.85
R2441	PLASTIC - SURE LUBE® DUST CAP	2.44"	.30#	\$4.48
R2716	PLASTIC - SURE LUBE® DUST CAP	2.72"	.30#	\$4.99

SPINDLE NUT * LOCK SHIELD * AND RIDGE GROOVE WASHER FOR RELIABLE TOOL® SPINDLES



PART #	DESCRIPTION	WT	PRICE
SN813	NUT FOR "COOKIE CUTTER" 13/16-20 THREAD - WIDTH 1.107"	.30#	\$1.39
LS813	"COOKIE CUTTER" LOCK SHIELD - 3/4" FITS OVER SN813 NUT FOR COTTER PIN LOCKING OF SPINDLE NUT	.30#	\$1.39
DW813	TABBED "D" WASHER - 3/4"	.30#	\$1.39

TO PLACE AN ORDER CALL 1-800-229-6690
OR FAX YOUR ORDER TO 1-800-359-8169

HOT DIP GALVANIZED FLAT BOAT TRAILER AXLES

1 1/16" PLAIN SPINDLE - 1200# CAPACITY
 1 1/2" GALV BOX TUBE - PRE DRILLED SPRING CENTERS



PART #	BEARING I/O	SEAL ID	SPRING CTR	TRACK (HUB FACE TO HUB FACE)	TIP TO TIP	WT	PRICE EACH
4080	44649 / 44649	1.25"	38 1/2"	51 1/4"	56 1/4"	15#	\$49.95
4081	44649 / 44649	1.25"	46 1/2"	59 1/2"	64 1/2"	17#	\$49.95
4082	44649 / 44649	1.25"	54"	68 1/8"	73"	20#	\$51.95

PLAIN SPINDLE WITH ROUND STUB STOCK

COMES WITH NUT, WASHER, AND COTTER PIN



NO BRAKE FLANGE

PART #	CAP PER PAIR	BEARINGS INNER / OUTER	A	B	C DIA	D DIA	E DIA	G DIA	WT	PRICE EA
0301	2000#	44643/44643	8"	4.3"	1"	1"	1.25"	1.25"	3.3#	\$8.95
0341	2500#	44649/44649	8"	4.3"	1 1/16"	1 1/16"	1.25"	1.25"	3.3#	\$8.95
0302	3500#	68149/44649	8"	4.175"	1 3/8"	1 1/16"	1.72"	1.75"	5.5#	\$9.95

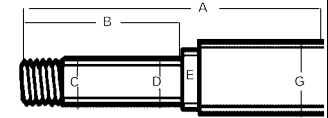

SPINDLE - LUBE® SPINDLES

NOW YOU CAN BUILD YOUR OWN AXLE WITH THE REVOLUTIONARY SPINDLE-LUBE® HUB LUBE SYSTEM BUILT IN. A HUB PACKING TOOL IS BUILT INTO EACH SPINDLE. AS YOU PUMP NEW GREASE INTO THE GREASE FITTING ON THE TIP OF THE SPINDLE, THE GREASE ENTERS THE HUB BETWEEN THE SEAL AND THE REAR BEARING. AS YOU CONTINUE TO PUMP NEW GREASE IN, YOU PURGE ALL OF THE OLD GREASE OUT THE FRONT OF THE HUB (SEE PAGE 2). THIS ALLOWS YOU TO REPACK THE HUB **WITHOUT REMOVING THE WHEEL AND HUB FROM THE TRAILER**. THE SPINDLE-LUBE® SPINDLE USES STANDARD HUBS OR HUB DRUMS.

PRICE INCLUDES DUSTCAP AND RUBBER PLUG

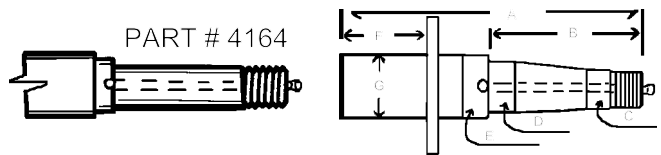

PART #	CAP PER PAIR	BEARINGS INNER / OUTER	A	B	C	D	E	F	G	WT	PRICE EACH
4164	2500#	44649 / 44649	8.25"	4.125"	1 1/16"	1 1/16"	1.25"		1.50" SQ	4.4#	\$15.95
0342	3500#	68149 / 44649	7.625"	4.175"	1 1/16"	1 3/8"	1.72"	1.88"	1.44" RD	5.5#	\$19.95
4165	6000#	25580 / 15123/14125A	11"	4.41"	1 1/4"	1 3/4"	2.25"	2"	1.44" RD	11#	\$29.95

REPLACEMENT SPINDLE PARTS

PART #	DESCRIPTION	WT	PRICE EACH
6003	ZINC COTTER PIN (X1 1/2)	.02#	\$0.05 EA.
6004	SS COTTER PIN (X1 1/2)	.02#	\$0.09 EA.
0308	1" TAB LOCK WASHER	.2#	\$1.29
0309	1" ID "D" SPINDLE WASHER	.3#	\$0.99
0304	3/4" ID SPINDLE WASHER	.25#	\$0.59
0306	1" ID SPINDLE WASHER	.3#	\$0.79
0305	3/4" SPINDLE NUT	.3#	\$1.09
0307	1" SPINDLE NUT	.4#	\$1.19



HEAVY DUTY WHEEL BEARING GREASE

EP-NLGL 2 HIGH GRADE - HI TEMP GREASE SPECIFICALLY INTENDED BY CHEVRON® FOR BOAT TRAILER HUBS THIS IS THE GREASE USED ON ALL CHAMPION SPINDLE-LUBE® AXLES



PART # CHV-14
 WT 1.5#
 PRICE / TUBE \$2.95

SPINDLE SEAL BY BEARING BUDDY®

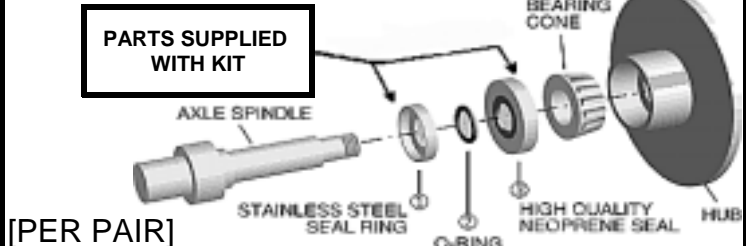

[PER PAIR]

AXLE SPRING PADS

PART #	AXLE TUBING SIZE	WT	PRICE
4168	2" WIDE SQUARE	.7#	\$1.69
4169	2 3/8" ROUND	1#	\$1.69
4170	3" ROUND	2#	\$2.25
4171	1 3/4" ROUND	.7#	\$1.69

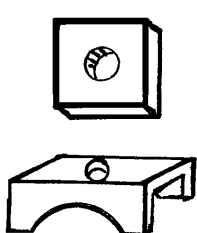

PART #	MODEL #	USE WITH BEARING BUDDY	FITS INNER BRG#	WT	PRICE /KIT
60001	KIT #1	1.980	44643	1#	\$11.95
60002	KIT #2	1.980	68149	1#	\$11.95
60005	KIT #5	1.980	44649	1#	\$11.95
60011	KIT#11	-----	25580	1#	\$16.95

C-HOOK SPRINGS

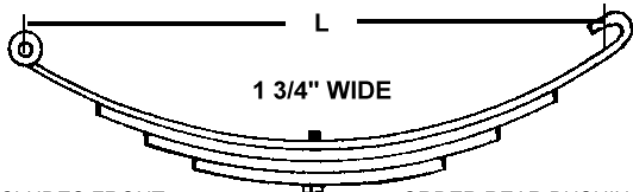

INCLUDES FRONT EYE SPRING BUSHING ONLY ORDER REAR BUSHING # 3006 SEPARATELY

PART #	DESCRIPTION	LEAF THICK	CAP PER SPRING	WT	PRICE EACH
1472	6 LF 21 1/2" C-HOOK	.29	1750#	16#	\$24.95
1473	6 LEAF 24" C-HOOK	.26	1875#	19#	\$25.95
3012	3 LEAF 26" C-HOOK	.36	1750#	14#	\$18.99
0429	4 LEAF 26" C-HOOK	.36	2000#	18#	\$20.99
0430	5 LEAF 26" C-HOOK	.36	2500#	21#	\$22.99

DOUBLE EYE SPRING



ON SINGLE AXLE TRAILER MEASURE FROM CENTER OF HANGER TO CENTER OF HANGER

PART #	DESCRIPTION	LEAF THICK	CAP PER SPRING	WT	PRICE EACH
AJ320	4 LEAF 20 1/4" DE	.26	1200#	12#	\$19.99
4208	4 LF 23" DE	.36"	2500#	14#	\$23.99
0401	4 LF 25 1/4" DE	.323"	1750#	13#	\$16.99
0402	4 LF 25 1/4" DE	.36"	2400#	16#	\$20.99
0403	5 LF 25 1/4" DE	.36"	2900#	19#	\$23.99
3018	6 LF 25 1/4" DE	.36"	3300#	21#	\$28.99
3019	4 LF 26" DE	.36"	1850#	17#	\$21.99
3022	4 LF 27" DE	.36"	1750#	17#	\$22.99
0235	6 LF 30" DE	.36"	2500#	25#	\$37.95

SLIPPER SPRINGS

ALSO MEASURE FROM CENTER OF BOLT HOLE TO CENTER OF SLIPPER END HANG POINT ON TRAILER

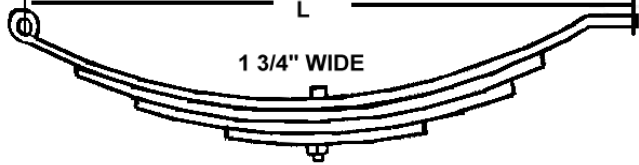

PART #	DESCRIPTION	LEAF THICK	CAP PER SPRING	WT	PRICE EA
0404	2 LF 24 1/2" SLIP	.24"	500#	8#	\$10.99
0405	3 LF 24 1/2" SLP	.24"	700#	9#	\$12.99
0406	4 LF 24 1/2" SLP	.24"	950#	11#	\$14.99
4210	5 LF 24 1/2" SLP	.24"	1150#	16#	\$18.99
5001	5 LF 24 1/2" SLP	.36"	2000#	17#	\$24.99
0236	5 LF 26" SLP	.27"	1200#	14#	\$28.95
3024	2 LF 30" SLP	.36"	880#	9#	\$16.99
3025	3 LF 30" SLP	.36"	1430#	12#	\$19.99
3026	4 LF 30" SLP	.36"	1830#	17#	\$21.99
3027	5 LF 30" SLP	.36"	2400#	21#	\$22.99
0433	4 LF 32" SLP	.29"	1100#	14#	\$20.95
0434	5 LF 32" SLP	.29"	1400#	17#	\$22.95
3029	6 LF 32" SLP	.29"	1750#	21#	\$25.95

GALVANIZED

AXLE U-BOLT TIE PLATE KITS

EACH KIT CONTAINS 2 EA GALVANIZED TIE PLATES
4 EA HOT DIP GALV U-BOLTS W/NUTS
AND LOCK WASHERS

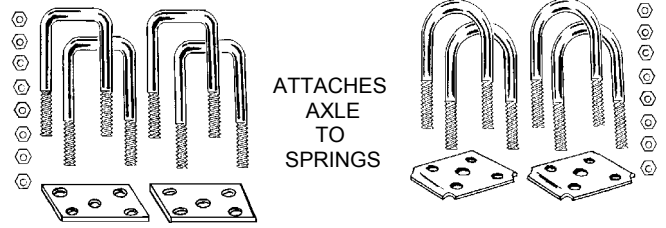

ATTACHES AXLE TO SPRINGS

PART #	AXLE SIZE	U-BOLT LGTH	WT	PRICE EA
1471	1 1/2" SQUARE	3 1/2" GALV	4.5#	\$13.95
1146	1 3/4" SQUARE	4 1/2" GALV	6.7#	\$14.95
3002	1 3/4" ROUND	4 1/2" GALV	6.7#	\$14.95
0415	2" SQUARE	5 5/16" GALV	8#	\$14.95
0441	2" SQUARE	4 5/16" GALV	8#	\$14.95
0416	2X3" RECTANGULAR	6 5/16" GALV	8#	\$15.95
0444	2 1/2 X 2 1/2" TUBE	5 5/16" GALV	8#	\$16.95
0417	2 3/8" ROUND	5 3/8" GALV	8#	\$14.95
0438	3" ROUND	6 11/16" GALV	9#	\$16.95

STAINLESS U-BOLTS WITH GALV TIE PLATES NOTE (**SS)

6007	2" SQUARE	5 1/4" SS	7.5#	\$21.95
6006	2" SQUARE	4 1/16" SS	7#	\$21.95
6122	2 X 3 RECTANGULAR	6 1/4" SS	8#	\$22.95

****SS NOTICE **** - WHEN INSTALLAING SS BOLTS, UBOLTS, OR LUG NUTS, DO NOT USE IMPACT WRENCHES, USE HAND TOOLS ONLY AND LUBRICATE THREADS WITH NEVER-SEEZ®. FAILURE TO INSTALL THE BOLTS FOLLOWING THESE PROCEDURES MAY CAUSE THREADS TO SEIZE. SEIZED THREADS ON SS BOLTS ARE NOT A WARRANTY CONDITION. NEVER-SEEZ® SOLD ON PAGE 19

BLACK IRON UTILITY TRAILER U-BOLT KITS

6008	2 3/8" ROUND	5 1/4" BLACK	8#	\$9.99
4507	3" ROUND	6 1/4" BLACK	10#	\$11.99

GRADE 5 SPRING BOLTS

PART # 0414 1/2 X 3 1/2" PLATED GR 5 BOLT	\$.95 WT .4#
PART # 0439 9/16 X 3 1/2" PLATED GR 5 BOLT	\$1.59 WT .5#
PART # 3010 5/8 X 4" GR 5 PLATED EQUALIZER BOLT FOR C-HOOK SPRING	\$2.59 WT .6#



NEW

CORROSION RESITANT COATED SPRINGS



5003	4 LF 25 1/4" DE SPG 1750# CAP	13#	\$21.99
5004	4 LF 25 1/4" DE SPG 2400# CAP	16#	\$25.99
0114	5 LF 25 1/4" DE SPG 2900# CAP	19#	\$28.99

**TANDEM EQUALIZERS
FOR 1 3/4" WIDE DOUBLE-EYE SPRINGS**
COMES WITH NYLON OR BRONZE BUSHINGS

PART #	LGTH	HGT	WT	PRICE	4" X 6 1/8"
0453	6 1/8"	4"	5#	\$11.95	
0453G	GALVANIZED		\$14.95		
0452	5 5/8"	N/A	7#	\$16.95	
STRAIGHT GALVANIZED					
0421	6 1/8"	2 1/2"	4#	\$11.95	2 1/2" X 6 1/8"
0421G	GALVANIZED		\$14.95		
0454	7 3/4"	3"	4.5#	\$11.95	3 X 7 3/4"
0454G	GALVANIZED		\$14.95		
3008	7"	N/A	5.5#	\$29.95	
C-HOOK EQUALIZER GALVANIZED 5/8" CENTER BOLT HOLE AND 9/16" SPRING BOLT HOLES					

BRONZE SPRING OR EQUALIZER BUSHING

FOR 1 3/4" WIDE SPRINGS
PART # 4217
WT .1#
PRICE EA \$3.99

11/16" OD X 9/16" ID
USE WITH GREASABLE BOLTS ONLY

NYLON SPRING BUSHINGS FOR 1 3/4" WIDE SPRINGS

PART #	OD	ID	WT	PRICE
0446	7/8"	1/2"	.1#	\$1.19/PR
0448	11/16"	9/16"	.1#	\$.99
0451	7/8"	9/16"	.1#	\$.99
3006	1"	9/16"	.1#	\$1.30

95% ZINC RICH COLD GALV SPRAY PRIMER

PART # 3032
WT 2#
PRICE \$6.95

NOTE CANNOT SHIP VIA AIR
UPS GROUND ONLY

USE AS TOUCH UP FOR GALVANIZED BOAT TRAILERS.
SUPERIOR ADHESION AND CORROSION RESISTANCE.
UNIQUE ELECTRO-GALVANIC "SELF-HEALING" PROCESS.
PRE-HEAT AREA TO BE SPRAYED FOR BEST RESULTS.

PART#	LENGTH	CTR HOLE	WT	PRICE
0410	2.25"		.4#	\$1.49
0411	2.5" FITS 2"	SQ U-BOLT	.4#	\$1.59
0412	3"		.5#	\$1.69
0442	3.5" FITS 3"	SQ U-BOLT	.5#	\$1.99
4009	4.5" FITS 4"	SQ U-BOLT	.6#	\$2.89
4013	5"		.6#	\$2.99
4218	X-HVY BLACK IRON	1/2" THICK X 2 1/2" SHACKLE LINK	.8#	\$2.49
6010	X-HVY GALV	1/2" THICK X 2 1/2" SHACKLE LINK	.8#	\$2.99

HOT DIP GALV 1/4" THICK SHACKLE LINKS

HOT DIP GALVANIZED BACKING PLATE FOR TRAILER ACCESSORIES
FITS 3" - 4" - OR 5" CHANNEL OR BOX TUBE
PART # 0443
WT 1#
PRICE EA \$2.99

BLACK IRON WELD ON SPRING HANGERS FOR 1 3/4" WIDE SPRINGS

PART #	HGT TO HOLE	WT	PRICE EACH
0419	1.5"	1#	\$1.95
0420	3.25"	2#	\$2.95
0422	4"	2.5#	\$3.95
0418	N/A	1#	\$1.95
0436	N/A	.6#	\$1.95

FRONT AND TANDEM HANGER FOR ALL 1 3/4" WIDE SPRINGS

REAR HANGER FOR D/E SPRINGS

REAR SLIPPER SPRING HANGER

UNPLATED SINGLE AXLE HANGER KIT FOR USE WITH DOUBLE EYE SPRINGS
USE W/3500# OR 6000# AXLES

KIT INCLUDES:
2 EA FRONT HANGERS
2 EA REAR HANGERS
4 SHACKLE LINKS
6 SPRING BOLTS (GRD 5)

PART # 4083
WT 9#
KIT PRICE \$12.95

UNPLATED HANGER KIT FOR USE WITH DOUBLE EYE SPRINGS & 3500# OR 6000# AXLES

KIT INCLUDES: ALL BOLTS, NUTS, SPRING HANGERS, EQUALIZERS, AND SHACKLE LINKS FOR APPROPRIATE AXLE CONFIGURATION

PART #	KIT DESCRIPTION	WT	PRICE
4084	TANDEM AXLE SPRING HANGER KIT	24#	\$32.95
4085	TRIPLE AXLE SPRING HANGER KIT	36#	\$45.95

TRAILER TIRES MOUNTED ON HOT DIP GALVANIZED RIMS

PART #	TIRE SIZE	MAX CAP	BOLT	TIRE OD	WT	LOAD RANGE	PRICE EA
3138	480 X 8B	590 #	4 ON 4	17"	13#	B	\$23.95
3139	480 X 8B	590 #	5 ON 4.5	17"	13#	B	\$23.95
4050	570 X 8C	910 #	4 ON 4	18.5"	18#	C	\$35.95
4051	570 X 8C	910 #	5 ON 4.5	18.5"	18#	C	\$35.95
0319	18.5 X 8.5 X 8	770#	4 ON 4	18"	24#	B	\$58.95
0320	18.5 X 8.5 X 8	770#	5 ON 4.5	18"	24#	B	\$58.95
3140	20.5 X 8 X 10E	1535 #	5 ON 4.5	20.5"	34#	E	\$89.95
3147	20.5 X 8 X 10E	1535#	5 ON 5.5	20.5"	34#	E	\$89.95
0325	480 X 12B	780 #	4 ON 4	20"	23#	B	\$41.95
0348	480 X 12B	780 #	5 ON 4.5	20"	23#	B	\$41.95
3141	530 X 12C	1045 #	4 ON 4	21.5"	28#	C	\$50.95
0349	530 X 12C	1045 #	5 ON 4.5	21.5"	28#	C	\$50.95
3142	ST175/80D13B	1065 #	4 ON 4	23.75"	38#	B	\$65.95
0318	ST175/80D13C	1315 #	5 ON 4.5	24"	38#	C	\$68.95
1486	ST185/80D13C	1480#	5 ON 4.5	24.5"	39#	C	\$78.95
4123	ST20575D14	1760 #	5 ON 4.5	26.75"	47#	C	\$84.95
4124	ST21575D14	1870 #	5 ON 4.5	27"	48#	C	\$96.95
4126	ST22575D15	2150 #	5 ON 4.5	29"	58#	C	\$103.95
3144	ST22575D15	2540 #	6 ON 5.5	29"	66#	D	\$113.95
0219	LT23585R16	3042#	8 ON 6.5	31.5"	76#	E	\$179.95

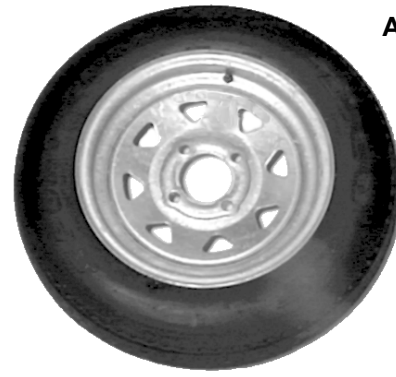

**NOTE:
ALL RIMS EXCEPT 8" AND 10" ARE SPOKE RIMS**

ALPHA NUMERIC TO METRIC TIRE SIZE CONVERSION CHART
 B7813 - ST175/80D13
 F7814 - ST20575D14
 G7814 - ST21575D14
 H7815ST - ST22575D15



HAVE ALL INFORMATION FROM SIDEWALL OF YOUR TIRE WHEN PLACING ORDER

HOT DIP GALVANIZED BOAT TRAILER RIMS

ALL RIMS EXCEPT 8" AND 10" ARE SPOKE TYPE



TIRES ONLY

PART #	TIRE SIZE	RIM WIDTH	BOLT	WT.	PRICE EA	PART #	TIRE SIZE	LOAD RANGE	MOUNTED TIRE OD	MAX. CAP	WT	PRICE
3145	8"	3.75"	4 ON 4	7#	\$14.80	3149	480 X 8	B	17"	590#	9#	\$15.95
3146	8"	3.75"	5 ON 4.5	7#	\$14.80	4603	570 X 8	C	18.5"	910#	13#	\$22.95
1487	10"	6"	5 ON 4.5	14#	\$29.95	3153	18.5 X 8.5 X 8	B	18"	770#	23#	\$38.95
1488	10"	6"	5 ON 5.5	14#	\$29.95	3150	20.5 X 8 X 10	E	20.5"	1535#	22#	\$49.95
0355	12"	4"	4 ON 4	15#	\$25.95	3151	480 X 12	B	20"	780#	13#	\$22.95
0356	12"	4"	5 ON 4.5	15#	\$25.95	3152	530 X 12	C	21.5"	1045#	15#	\$29.95
3148	13"	4.5"	4 ON 4	17#	\$29.95	0331	ST175/80D13C	C	24"	1315#	23#	\$39.95
0326	13"	4.5"	5 ON 4.5	17#	\$29.95	1489	ST185/80D13C	C	24.5"	1480#	24#	\$46.95
0327	14"	6"	5 ON 4.5	23#	\$36.95	4600	ST20575D14	C	26.75"	1760#	27#	\$49.95
0328	15"	6"	5 ON 4.5	29#	\$42.95	4601	ST21575D14	C	27"	1870#	28#	\$51.95
0329	15"	6"	6 ON 5.5	29#	\$45.95	4602	ST22575D15	C	29"	2150#	37#	\$64.95
						3154	ST22575D15	D	29"	2540#	41#	\$74.95

SPARE TIRE CARRIERS

LOCKABLE U-BOLT SPARE TIRE CARRIER

ZINC PLATED
 FITS UP TO
 3X4" BOX TUBE
 4 OR 5 LUG HUBS
 LOCK NOT INCLUDED

PART # 0310
WT 2.5#
PRICE EA \$6.49



GALVANIZED HI-MOUNT SPARE TIRE CARRIER

WITH MOUNTING
 HARDWARE
 FITS UP TO
 3X4" TONGUE
 FITS 4, 5, OR
 6 LUG RIMS

PART # 6042
WT 8#
PRICE EA \$19.95

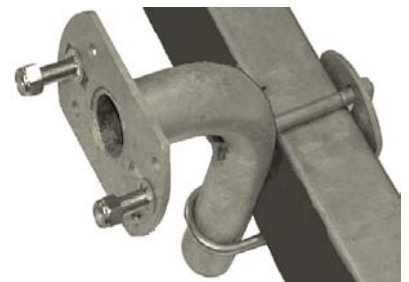

**GOODYEAR®
MARATHON®
RADIAL TRAILER
TIRES**

(TIRE ONLY)



PART #	DESCRIPTION	MAX CAP	WT	PRICE
P8100	ST175/80R13 LRC GOODYEAR RADIAL	1360#	19#	\$64.95
20514GY	ST205/75R14 LRC GOODYEAR RADIAL	1760#	23#	\$76.95
20515GY	ST205/75R15 LRC GOODYEAR RADIAL	1820#	25#	\$81.95
P605	ST225/75R15 LRD GOODYEAR RADIAL	2540#	30#	\$94.95

**ALUMINUM
STAR RIM**

(RIMS ONLY)



0330	14" - 545 BOLT PATTERN ALUMINUM STAR RIM	22#	\$88.95
0332	15" - 545 BOLT PATTERN ALUMINUM STAR RIM	24#	\$98.95
0333	15" - 6 LUG BOLT PATTERN ALUMINUM STAR RIM	25#	\$99.95

PAINTED RIMS

(RIMS ONLY)



0119	14" WHITE SPOKE 545 BOLT PATTERN RIM ONLY	20#	\$27.95
0120	14" WHITE SPOKE 550 BOLT PATTERN RIM ONLY	20#	\$27.95
0121	15" WHITE SPOKE 545 BOLT PATTERN RIM ONLY	25#	\$32.95
4131	15" WHITE SPOKE 550 BOLT PATTERN RIM ONLY	25#	\$32.95
0123	15" WHITE SPOKE 665 - 6 LUG BOLT PATTERN	25#	\$34.95

**PAINTED SPOKE RIMS
WITH CARLISLE
USA TRAIL® TIRES**

MOUNTED



0124	205/75D14 LRC ON WHITE SPOKE RIM - 545	45#	\$74.95
0125	205/75D14 LRC ON WHITE SPOKE RIM - 550	45#	\$74.95
0126	225/75D15 LRC ON WHITE SPOKE RIM - 545	56#	\$94.99
0127	225/75D15 LRC ON WHITE SPOKE RIM - 550	56#	\$94.99
0128	225/75D15 LRD ON WHITE SPOKE RIM - 655	59#	\$99.95

**SLIME®
FOR TUBELESS TIRES**

PART # 5D500
16 OZ TUBE

WT 1/5#

PRICE PER TUBE \$8.99



PART # 5D1G
1 GALLON
WITH PUMP

WT12#

PRICE PER GAL \$48.95



HFOR SHIPPING PURPOSES WEIGHT OF EITHER ONE OR TWO TANDEM FENDERS WILL BE 70# AS PER "UPS"

HOT DIP GALVANIZED SINGLE AXLE UNDERCARRIAGE SLIDERS



FOR 25 1/4" D/E SPRINGS WITH FENDER STEP PADS
SOLD PER PAIR
ORDER MOUNTING HARDWARE SEPARATELY

PART #	SIZE	WT	PRICE/PR
3299	25 1/4" SPRINGS - 13" TIRES	40#	\$56.50
3300	25 1/4" SPRINGS - 14" TIRES	40#	\$59.50

HOT DIP GALVANIZED ANGLE IRON UNDERCARRIAGE SPRING SLIDERS FOR SINGLE AXLE TRAILER



PURCHASE MOUNTING BOLTS AND FENDER BRACKETS SEPARATELY
SOLD PER PAIR

PART #	PAIR OF SLIDERS FOR	WT	PRICE/PR
4229	24" SLIPPER SPRINGS	30#	\$49.95
4230	30" SLIPPER SPRING	30#	\$49.95
4231	25 1/4" DOUBLE EYE SPRING	30#	\$49.95

HOT DIP GALVANIZED TANDEM AXLE ANGLE IRON UNDERCARRIAGE SLIDERS W/FENDER STEP PADS

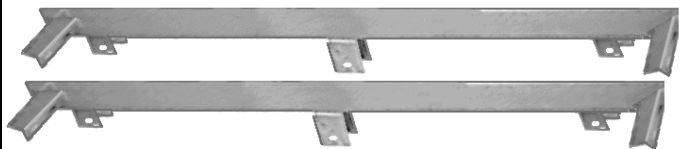

FITS FENDER #0611 FOR 25 1/4" D/E SPRINGS
ORDER MOUNTING HARDWARE SEPARATELY

PART #	TIRE SIZE	WT	PRICE/PR
0605	25 1/4" D/E SPRING - 14" TIRES	67#	\$119.95

GALVANIZED TANDEM FENDER

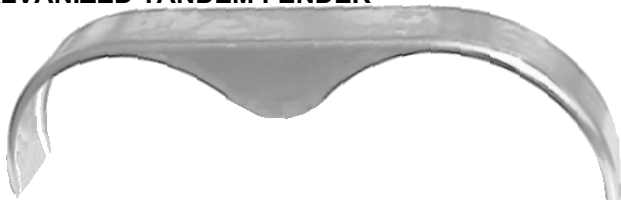

PART #	DESCRIPTION	WT	PRICE
0611	WITH DROP VALENCE FOR 14" AND 15" TIRES 64" L X 16 1/2" H X 8 1/2" W	23#	\$44.95
0156	WDROP VALENCE FOR 13" TIRES 55 1/2" L X 10 1/4" H X 7 1/2" W (FITS MAGIC TILT® 13")	21#	\$39.95

FAX YOUR ORDER TO 1-800-359-8169
OR CALL 1-800-229-6690

NOTE: FENDER MEASUREMENTS MAY VARY (+ -) 1/2" FROM CATALOG

ZINC GALV SINGLE FENDERS

CAN BE PAINTED

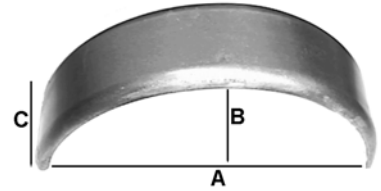

PART #	TIRE SIZE	A	B	C	WT	PRICE
0609	13"	28"	10"	8.5"	11#	\$14.95
0610	14"	31.5"	15.5"	8.5"	13#	\$18.95
0616	15"	32"	15.5"	9"	15#	\$21.95

ZINC GALV MUSHROOM STYLE FENDERS

CAN BE PAINTED



PART #	TIRE SIZE	A	B	C	WT	PRICE
0608	8"/12"	24"	6"	7"	6#	\$14.95
0607	13"/14"	28 3/4"	7"	9"	9#	\$17.95

ALUMINUM CHECK PLATE JEEP STYLE FENDERS

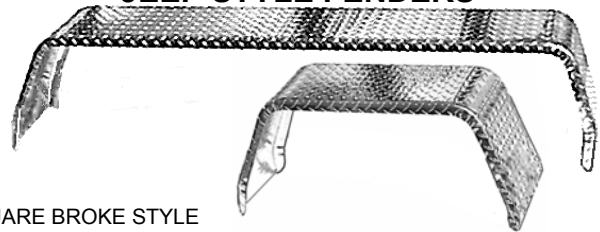

SQUARE BROKE STYLE

0612 - SINGLE	14"/15"	32"	14"	10"	7.5#	\$43.90
0613 - TANDEM	14"/15"	68"	16"	10"	13#	\$63.90

HOT DIP GALVANIZED FENDER MOUNTING BRACKETS

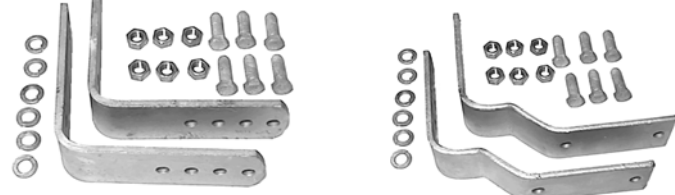

PART #	DESCRIPTION	WT	PRICE/KIT
4010	STANDARD FENDER MOUNTING BRACKETS (PR W/BOLTS)	4.5#	\$13.95
1546	OFFSET FENDER MOUNTING BRACKETS (PR W/BOLTS)	4.5#	\$13.95

HOT DIPPED GALV SPRING MOUNTING BRACKETS FOR 1 3/4" WIDE SPRINGS

ORDER U-BOLTS OR STRAIGHT BOLTS SEPARATELY

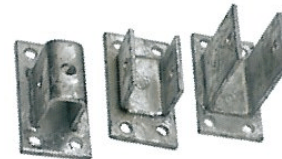

PART #	DESCRIPTION	WT	PRICE EA
4212	REAR DE SPRING HANGER	4#	\$12.95
4213	FRONT SPRING HANGER	4#	\$12.95
4214	LONG CENTER HANGER	4.5#	\$12.95

BLACK IRON UNPAINTED SINGLE FENDER

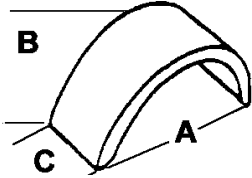

BLACK IRON FENDER BACK FOR SINGLE FENDER



PART #	A	B	C	WT	PRICE EA
4112 - FENDER	32"	15"	9"	11#	\$15.95
4373 - BACK	30.5"	12"	N/A	7#	\$5.99

BLACK IRON UNPAINTED TANDEM FENDER

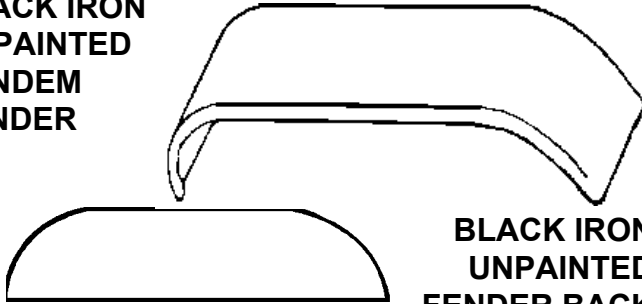

BLACK IRON UNPAINTED FENDER BACK FOR TANDEM FENDER

4114 - FENDER	70"	17"	9"	20#	\$22.95
4374 - BACK	70"	12"	N/A	13#	\$7.95

BLACK IRON UNPAINTED TANDEM FENDER WITH DROP VALANCE

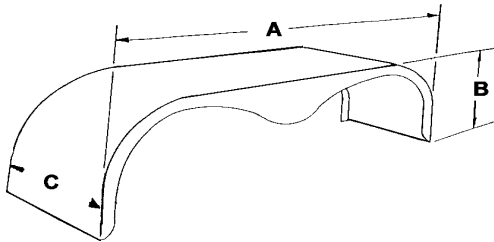

0614 - FENDER	70"	17"	9"	25#	\$33.95
---------------	-----	-----	----	-----	---------

** FENDER BACK 4374 ABOVE FITS THIS FENDER AS WELL **

FLUID FILM® MARINE RUST AND CORROSION PREVENTATIVE

USED FOR MORE THAN 30 YEARS IN OCEAN GOING VESSELS AND INDUSTRIAL APPLICATIONS REQUIRING LONG LASTING PROTECTION IN HIGHLY CORROSIVE ENVIRONMENTS.

SUPERIOR PROTECTION ON BOATS - MOTORS - TRUCKS - TRAILERS - MACHINERY AND BATTERY TERMINALS

ALWAYS ACTIVE - WILL NOT DRY OUT

11 3/4 OZ SPRAY CAN

PART # 3319

WGT 1# SHIP VIA UPS GROUND ONLY



PRICE EA \$7.95

95% ZINC RICH COLD GALV SPRAY PRIMER

PART # 3032 WT 2#

PRICE \$6.95

SHIPS VIA UPS GROUND ONLY

USE AS TOUCH UP FOR GALVANIZED BOAT TRAILERS. SUPERIOR ADHESION AND CORROSION RESISTANCE. UNIQUE ELECTRO-GALVANIC "SELF-HEALING" PROCESS. PRE-HEAT AREA TO BE SPRAYED FOR BEST RESULTS.



LIQUID ROLLERS

SPRAY ON COATING FOR BUNK BOARD CARPET.

MAKES YOUR CARPET AS SLICK AS ROLLERS!!

LONG LASTING, FRICTION REDUCING NON STAINING COATING.

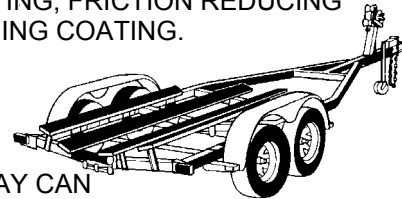

10 OZ SPRAY CAN

PART #3038

WT. 2#

PRICE PER CAN \$8.98 SHIPS VIA UPS GROUND ONLY

PAIR OF 5' LONG GALVANIZED ROLLER BUNKS
ORDER MOUNTING BRACKETS SEPARATELY.

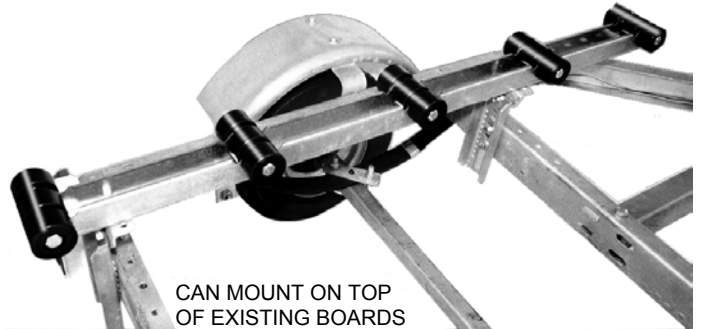

CAN MOUNT ON TOP OF EXISTING BOARDS

PART #: 86118

WT: 40#

PRICE PER PAIR \$69.95

HOT DIP GALVANIZED ROLLER BUNK BRACKET

ORDER MOUNTING BOLTS SEPARATELY

1401	8" BRACKET COMPLETE	2.5#	\$4.99
1402	10" BRACKET COMPLETE	3#	\$5.99
1403	12" BRACKET COMPLETE	3.5#	\$6.99



FAX YOUR ORDER TO 1-800-359-8169

OR CALL 1-800-229-6690

www.championtrailers.com

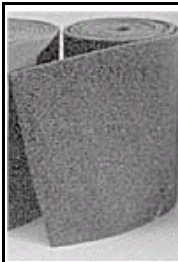

**HEAVY MARINE CARPET
VINYL BACKED - SOLD PER LINEAL FOOT**

\$1.95/FT 9" WIDE WT .3#	\$1.25/FT 12" WIDE WT .35#	\$1.85/FT 18" WIDE WT .4#	\$5.49/FT 6 FT WIDE WT 1.7#
#1415 BLACK	#1416 BLACK	#1418 BLACK	#1477 BLACK
#1419 GREY	#1420 GREY	#1421 GREY	#1476 GREY

**2 x 6" CARPETED BUNK BOARDS
SOLD PER FOOT WITH STAINLESS STAPLES**



PART # 4334 MAXIMUM SHIPABLE LENGTH 7 FT.
WT PER FT 3#
PRICE PER FT \$3.95

2 X 4" CARPETED BUNK BOARDS

4033	CARPETED 2X4 BUNK BOARD 5' LG	8#	\$12.95
------	-------------------------------	----	---------

ZINC PLATED STAR WASHERS
LOCKS KEEL ROLLER BRACKETS
OR BUNK BRACKETS IN PLACE
TO KEEP THEM FROM SLIPPING



PART #	BOLT SIZE	WT	PRICE EA
1408	3/8"	.2#	\$0.69
1404	7/16"	.2#	\$0.69
1404A	1/2"	.2#	\$0.69

STAINLESS CARRIAGE BOLT
BOLTS BUNK BOARD TO BUNK BRACKET

3101	1/4 X 2 1/2"	.1#	\$1.39
3102	3/8 X 2 1/2"	.2#	\$1.49
3103	3/8 X 3"	.25#	\$1.59



STAINLESS STEEL LAG SCREW
CONNECTS BUNK BOARD TO BRACKET

3110	1/4 X 1 1/4"	.1#	\$0.49
3111	3/8 X 1 1/4"	.2#	\$0.59



**304 STAINLESS STEEL
CARPET NAILS**

5/16" DIA HEAD
.109 DIA SHAFT
1" LONG
PART # 1542 (100 PER BAG)
WT 2# **PRICE/BAG \$8.95**

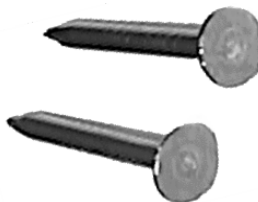

**HOT DIP GALVANIZED
VERTICAL BUNK BRACKET**

2 X 4" OR 2 X 6" BUNK BOARD
USES CARRIAGE BOLT # 3101

PART #	DESCRIPTION	WT	PRICE
1407	6" VERTICAL BKT	1.5#	\$4.95
1405	8" VERTICAL BKT	2#	\$4.95
3192	10" VERTICAL BKT	2.5#	\$5.95

ORDER BOLTS
SEPARATELY

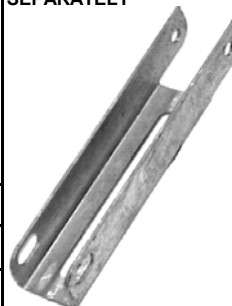

**HEAVY DUTY
PVC GUIDE POST KIT**

STANDS 5' HIGH
HOT DIP GALVANIZED 11 GAUGE
1 1/2" BOX TUBE POST
COMPLETE WITH
MOUNTING HARDWARE
PRICE PER KIT \$59.95

PART #	FRAME SIZE	WT
4015	3" CHANNEL	36#
4016	4" CHANNEL	37#
4017	5" CHANNEL	38#
4018	3 X 3 BOX TUBE	37#
4019	3 X 4 BOX TUBE	38#
4020	3 X 5 BOX TUBE	39#

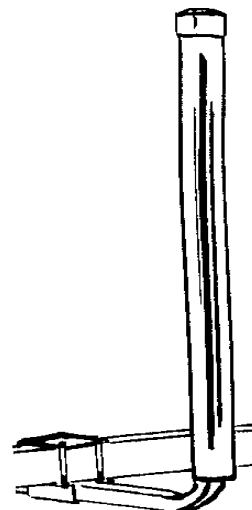

**5' - 2 X 4 GUIDE BOARD KIT
WITH HEAVY
1/4" X 3"
GALVANIZED
FLAT BAR**

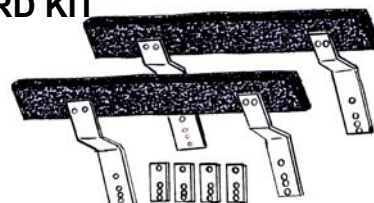

PART 4035	FOR 3" TO 5" CHANNEL FRAME	49#	\$54.95
PART 4036	FOR 3" TO 5" BOXTUBE FRAME	49#	\$54.95

**HOT DIP GALVANIZED
SWIVEL TOP BUNK BRACKET**
COMES W/BUNK BKT, ANGLE TOP CLIP
AND HOT DIP GALV TOP BOLT W/ NUT.
ORDER MOUNTING BOLTS
SEPARATELY

PART#	BRACKET HEIGHT	WT	PRICE
1401	8" COMPLETE	2.7#	\$4.99
1402	10" COMPLETE	3#	\$5.99
1403	12" COMPLETE	3.5#	\$6.99
1480	8" BRACKET ONLY NO TOP BRACKET	2#	\$3.99
1481	10" BRACKET ONLY NO TOP BRACKET	2.7#	\$4.99
1482	12" BRACKET ONLY NO TOP BRACKET	3#	\$5.99
3197	ANGLE TOP BRACKET ONLY (NO BOLT)	.4# 3/8" HOLE	\$1.99 DIA SIZE



X-HVY GALVANIZED ANGLE TOP CLIP
3/16" THICK ANGLE

USE 3/8" DIA LAG SCREWS 1/2" DIA HOLE



DESC	WT	PRICE
#3195 SOLD EACH	.8#	\$2.99
#3196 AS UPGRADE TO #1401, 1402, 1403	.4#	\$1.00

BLACK HEAVY "V" KEEL ROLLERS
NYLON BUSHINGS



PART #	ROLLER SIZE	HOLE SIZE	WT	PRICE
0801	8" RUBBER	5/8"	4#	\$5.95
0806	8"X-HVY RUBBER	5/8"	4.5#	\$6.95
0802	10" RUBBER	5/8"	4.5#	\$6.95
0803	12" RUBBER	5/8"	5#	\$7.95
1493	12" X-HVY RUBBER	5/8"	6#	\$8.95
0804	18" RUBBER	5/8"	10#	\$23.99
0805	3" BLK END CAP	5/8"	.6#	\$1.99

BLACK RUBBER SPOOL KEEL ROLLERS



PART #	ROLLER SIZE	HOLE SIZE	WT	PRICE
L502	4" RUBBER	1/2"	1.5#	\$2.99
L503	4" RUBBER	5/8"	1.5#	\$2.99
L504	5" RUBBER	1/2"	2#	\$3.99
L805	5" RUBBER	5/8"	2#	\$3.99
L806	5" X-HVY RUBBER	5/8"	2.5"	\$4.99

11 GAUGE HOT DIP GALV KEEL ROLLER BRACKETS

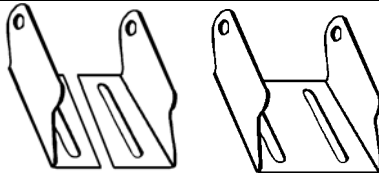

5/8" DIA HOLE SIZE
ORDER MOUNTING BOLTS SEPARATELY SEE PAGES 18 AND 19

PART #	DESCRIPTION	B/W HOLES	WT	PRICE
0817	SPLIT ROLLER BRACKETS (PR)	N/A	2#	\$5.99
M011	4" ROLLER BRACKET	1.5"	2#	\$4.99
M012	5" ROLLER BRACKET	3.5"	2.7#	\$5.99
0818	8" ROLLER BRACKET	5.5"	3#	\$6.99
0819	10" ROLLER BRACKET	7.5"	4#	\$7.99
0820	12" ROLLER BRACKET	9.5"	5#	\$8.99

ZINC PLATED KEEL ROLLER PINS W/PAL NUT END CAPS



USE GREASE WHEN ASSEMBLING

PART #	ROLLER SIZE	LOA	PIN OD	WT	PRICE
CH02	4"	5.25"	1/2"	.4#	\$1.55
CH03	5"	6.25"	1/2"	.5#	\$1.95
CH04	5"	6.25"	5/8"	.6#	\$2.35
0807	8"	9.25"	5/8"	.7#	\$2.85
0808	10"	11.25"	5/8"	1#	\$3.25
0809	12"	13.25"	5/8"	1.5#	\$3.65
0810	18"	19.25"	5/8"	2#	\$4.95

6125 ADD 2" LENGTH TO ANY ROLLER PIN FOR END CAP ROLLERS .2# \$0.90

PAL NUT ROLLER PIN END CAPS

M014	1/2" PAL NUT FOR 1/2" DIA PIN	.1#	\$.37
M015	5/8" PAL NUT FOR 5/8" DIA PIN	.1#	\$.39



GRAY STRAIGHT SIDE GUIDE ROLLER

END CAPS TO FIT ROLLER

12" X 2 1/2" OD



PART # M008

WGT 4.5#

USES 5/8" DIA ROLLER PIN

PART # 0902

WGT .8#

PRICE EA END CAP \$1.95

PRICE - ROLLER ONLY \$9.95

SUPER TOUGH YELLOW POLYURETHANE "V" ROLLER



PART #	ROLLER SIZE	HOLE SIZE	WT	PRICE
RP8	8" POLY	5/8"	3#	\$17.95
RP10	10" POLY	5/8"	3.5#	\$19.95
RP12	12" POLY	5/8"	4.5#	\$21.95
4327	3" END CAP	5/8"	.6#	\$6.99

SUPER TOUGH YELLOW POLYURETHANE SPOOL ROLLERS



PART #	ROLLER SIZE	HOLE SIZE	WT	PRICE
4320	4" POLY	1/2"	1.5#	\$6.95
4321	4" POLY	5/8"	1.5#	\$6.95
4322	5" POLY	1/2"	2#	\$7.98
4323	5" POLY	5/8"	2#	\$7.98

SUPER TOUGH YELLOW POLYURETHANE STRAIGHT ROLLER

12" LENGTH AND 5/8" DIA. HOLE



PART # RP212

WT 4.5#

PRICE EA \$23.95

CLEAR YELLOW POLY ROLLERS

4" DIA X 3" WIDE
FITS EZ LOADER
1 OR 1 1/16" SHAFT DIA.
DOES NOT NEED NYLON BUSHING
PURCHASE WASHERS SEPARATELY



PART # 4237

WT 1.5#

PRICE \$10.85

STAINLESS STEEL KEEL ROLLER PINS

5/8" DIAMETER

DRILLED FOR 1/8" COTTER PINS
INCLUDES 2 PINS

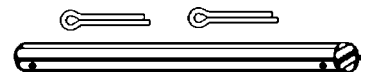

PART #	ROLLER SIZE	LOA	WT	PRICE EA
4324	8"	9 3/8"	1#	\$6.99
4325	10"	11 3/8"	1.5#	\$7.99
4326	12"	13 3/8"	2#	\$9.99

STAINLESS STEEL BOLTS AND UBOLTS

STAINLESS STEEL NOTICE - WHEN INSTALLING SS BOLTS, UBOLTS, OR LUG NUTS, **DO NOT USE IMPACT TOOLS.** USE HAND TOOLS ONLY AND LUBRICATE THREADS WITH A THREAD LUBRICANT LIKE NEVER-SEEZ®. FAILURE TO INSTALL THE BOLTS FOLLOWING THESE PROCEDURES MAY CAUSE THREADS TO SEIZE.
SEIZED THREADS ON SS BOLTS ARE NOT A WARRANTY CONDITION!!

STAINLESS STEEL UBOLTS				
1/2" SQUARE BEND W / SS LOCK NUTS				
PART #	WIDTH	LENGTH	WT	PRICE
4313	2 1/16"	4 5/16"	.7#	\$4.89
4311	2 1/16"	5 5/16"	.9#	\$4.99
4312	2 1/16"	6 5/16"	1.1#	\$5.09
4242	3 1/16"	4 5/16"	1#	\$4.99
4316	3 1/16"	5 5/16"	1.1#	\$5.39
0101	3 1/16"	6 5/16"	1.2#	\$5.99
4317	3 1/16"	7 5/16"	1.3#	\$6.39



STAINLESS STEEL

SS HEX HEAD BOLTS WITH LOCK NUTS			
PART #	SIZE	WT	PRICE
4514	1/4-20 X 1"	.1#	\$0.38
4515	1/4-20 X 1 1/4"	.1#	\$0.44
4516	1/4-20 X 1 1/2"	.1#	\$0.49
4517	1/4-20 X 2"	.1#	\$0.59
4518	1/4-20 X 2 1/2"	.1#	\$0.69
4519	1/4-20 X 3"	.1#	\$0.79
3105	3/8-16 X 1"	.1#	\$0.79
3106	3/8-16 X 1 1/4"	.1#	\$0.86
4495	3/8-16 X 1 1/2"	.1#	\$0.95
4496	3/8-16 X 2"	.2#	\$1.02
4508	3/8-16 X 2 1/2"	.2#	\$1.10
4509	3/8-16 X 3"	.2#	\$1.18
4510	3/8-16 X 3 1/2"	.3#	\$1.29
4511	3/8-16 X 4"	.3#	\$1.47
4512	3/8-16 X 5"	.4#	\$1.79
4513	3/8-16 X 6"	.4#	\$1.98
3107	7/16-14 X 1"	.2#	\$0.79
3108	7/16-14 X 1 1/4"	.2#	\$0.89
4497	1/2-13 X 1"	.2#	\$0.99
4498	1/2-13 X 1 1/2"	.2#	\$1.19
4499	1/2-13 X 2"	.2#	\$1.39
4500	1/2-13 X 3"	.3#	\$1.79
4501	1/2-13 X 4"	.4#	\$1.99
4502	1/2-13 X 5"	.4#	\$2.19
4503	1/2-13 X 6"	.5#	\$2.49
4504	1/2-13 X 7"	.5#	\$3.42
4505	1/2-13 X 8"	.5#	\$3.79
4506	1/2-13 X 9"	.6#	\$4.39

(SOLD EACH)

STAINLESS STEEL



SS HEX HEAD 18/8 LAG SCREWS (SOLD EACH)			
PART #	SIZE	WT	PRICE
3110	1/4 X 1 1/4"	.1	\$0.49
3112	1/4 X 2"	.1	\$0.59
3111	3/8 X 1 1/4"	.1	\$0.59
3113	3/8 X 2"	.2	\$0.68
3114	3/8 X 3"	.2	\$0.89

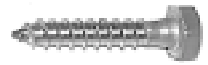

STAINLESS STEEL NYLON LOCK NUTS (BAG OF 10)			
PART #	SIZE	WT	PRICE
2068	8/32	.1#	\$1.29
2069	10/32	.1#	\$1.59
2070	1/4-20	.2#	\$1.95
2071	3/8-16	.3#	\$2.97
2072	7/16-14	.4#	\$4.86
2073	1/2-13	.5#	\$5.88

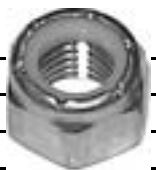

STAINLESS STEEL FLAT WASHERS (BAG OF 10)			
PART #	SIZE	WT	PRICE
4520	8/32"	.1#	\$0.49
4521	1/4"	.1#	\$0.59
4522	3/8"	.1#	\$0.69
4523	7/16"	.2#	\$0.79
4524	1/2"	.2#	\$0.99



STAINLESS CARRIAGE BOLT BOLTS BUNK BOARD TO BUNK BRACKET			
PART#	SIZE	WT	PRICE
3101	1/4 X 2 1/2"	.1#	\$1.19
3102	3/8 X 2 1/2"	.2#	\$1.29
3103	3/8 X 3"	.25#	\$1.39



STAINLESS STEEL ALL-THREAD ROD			
EACH PIECE IS 36" LONG			
PART #	SIZE	WT	PRICE
4525	3/8" X 36" LONG	3#	\$9.95
4526	1/2" X 36" LONG	4#	\$12.95
4527	5/8" X 36" LONG	6#	\$12.95
4528	3/4" X 36" LONG	8#	\$18.95



STAINLESS STEEL LUG NUTS			
13/16" OD X 1/2" - 20			
PART #	DESCRIPTION	WT	PRICE
6065	SS LUG NUT (SINGLE)	.25	\$1.69
6066	SS LUG NUT (BAG OF 10)	2.5#	\$15.00



3/8 X 1 9/16 X 2" STAINLESS UBOLT			
FITS EZ LOADER® ROCKER ARM ASSEMBLY			
PART #	WT.	PRICE	
6016	.3#	\$2.49	



HOT DIP GALVANIZED 1/2" ROUND U-BOLTS WITH NUTS & LOCK WASHERS				
PART #	"A" WIDTH	"B" LENGTH	WT	PRICE EA
4300	2 7/16"	5 3/8"	.9#	\$2.89
4301	3 1/16"	6 11/16"	1.1#	\$3.29

ZINC PLATED 1/2" ROUND U-BOLTS WITH SELF LOCKING NUTS				
2014	1 3/4"	4 1/2"	.8#	\$2.79

HOT DIP GALVANIZED 3/8" SQUARE U-BOLTS				
0100	1 9/16"	3 1/2"	.5#	\$2.19
0107	2 1/16"	2 7/8"	.5#	\$2.19

HOT DIP GALVANIZED 7/16" SQUARE U-BOLTS WITH NUTS & LOCK WASHERS				
0108	2 1/16"	3 1/16"	.8	\$2.49
4302	3 1/16"	4 5/16"	.8#	\$2.69
4303	3 1/16"	3 5/16"	.8#	\$2.59
4304	4 1/16"	2 13/16"	.8#	\$2.69

HOT DIP GALVANIZED 1/2" SQUARE U-BOLTS WITH NUTS & LOCK WASHERS				
4309	1 3/4"	4 1/2"	.8#	\$2.79
0109	1 13/16"	3 7/16"	.7#	\$2.69
4314	2 1/16"	4 5/16"	.8#	\$2.79
4305	2 1/16"	5 5/16"	.9#	\$2.89
4306	2 1/16"	6 5/16"	1#	\$2.99
0110	2 1/16"	7 5/16"	1#	\$3.19
2010	2 9/16"	5 5/16"	1#	\$2.99
4307	3 1/16"	4 5/16"	1#	\$2.89
4308	3 1/16"	5 5/16"	1.1#	\$2.99
4310	3 1/16"	6 5/16"	1.2#	\$3.29
0106	3 1/16"	7 5/16"	1.3#	\$3.49
2011	3 9/16"	5 5/16"	1.2#	\$3.49
0111	4 1/16"	4 5/16"	1.2#	\$3.69
2012	4 1/16"	5 5/16"	1.3#	\$3.89
2013	4 1/16"	6 5/16"	1.4#	\$3.99

HOT DIP GALVANIZED NUTS AND WASHERS			
PART #	DESC	WT	PRICE
3211	3/8" FLAT WASHER	.1#	\$0.09
3212	3/8" LOCK WASHER	.1#	\$0.09
3209	3/8" NUT	.1#	\$0.09
3215	7/16" FLAT WASHER	.1#	\$0.16
3216	7/16" LOCK WASHER	.1#	\$0.16
3210	7/16" NUT	.1#	\$0.16
3213	1/2" FLAT WASHER	.1#	\$0.19
3214	1/2" LOCK WASHER	.1#	\$0.19
3217	1/2" NUT	.1#	\$0.19

NEVER SEEZ® ANTI-SEIZE AND ANTI-CORROSION COMPOUND FOR USE WITH STAINLESS BOLTS AND NUTS			
PART #	DESCRIPTION	WT	PRICE/CAN
3033	1/4# FLAT TOP CAN	.25#	\$7.99
3034	1/2# BRUSH TOP CAN	.5#	\$10.29



HOT DIP GALVANIZED STRAIGHT BOLTS WITH NUT & LOCK WASHER			
PART #	BOLT SIZE	WT	PRICE
4232	3/8 X 1"	.1#	\$0.39
3201	3/8 X 1 1/4"	.1#	\$0.49
4318	3/8 X 1 1/2"	.2#	\$0.59
4319	3/8 X 2"	.2#	\$0.69
2020	3/8 X 3"	.3#	\$0.79
2021	3/8 X 4"	.3#	\$0.89
2022	3/8 X 5"	.4#	\$0.99
2023	3/8 X 6"	.4#	\$1.09
3199	7/16 X 1"	.2#	\$0.49
3200	7/16 X 1 1/4"	.3#	\$0.55
4233	1/2 X 1"	.2#	\$0.59
4234	1/2 X 1 1/2"	.3#	\$0.69
4235	1/2 X 2"	.4#	\$0.79
4236	1/2 X 3"	.5#	\$0.89
3202	1/2 X 4"	.6#	\$0.99
32025	1/2 X 4.5"	.6#	\$1.04
3203	1/2 X 5"	.7#	\$1.09
32035	1/2 X 5.5"	.7#	\$1.14
3204	1/2 X 6"	.8#	\$1.19
32045	1/2 X 6.5"	.8#	\$1.29
3205	1/2 X 7"	.9#	\$1.39
32055	1/2 X 7.5"	.9#	\$1.49
3206	1/2 X 8"	1#	\$1.59
3207	1/2 X 9"	1.1#	\$1.99
3208	1/2 X 10"	1.2#	\$2.29

ZINC PLATED BOLTS WITH SELF LOCKING NUTS			
PART#	SIZE	WT	PRICE
3218	3/8 X 2.5"	.2#	\$0.65
3219	3/8 X 3"	.3#	\$0.69
3220	3/8 X 3.5"	.3#	\$0.75
3222	3/8 X 4"	.4#	\$0.79
3223	3/8 X 4.5"	.4#	\$0.85
3224	3/8 X 5"	.5#	\$0.90
3225	3/8 X 5.5"	.5#	\$0.95
3226	3/8 X 6"	.6#	\$0.99
3227	3/8 X 6.5"	.6#	\$1.09
3228	1/2 X 1.25"	.2#	\$0.69
0414	1/2 X 3.5"	.4#	\$0.95
4492	1/2 X 4.5"	.5#	\$1.19
3230	5/8 X 3"	.3#	\$2.19
3010	5/8 X 4"	.5#	\$2.59
3232	5/8 X 4.5"	.5#	\$2.79
4241	5/8 X 5"	.7#	\$2.89
4239	5/8 X 8"	.9#	\$3.69

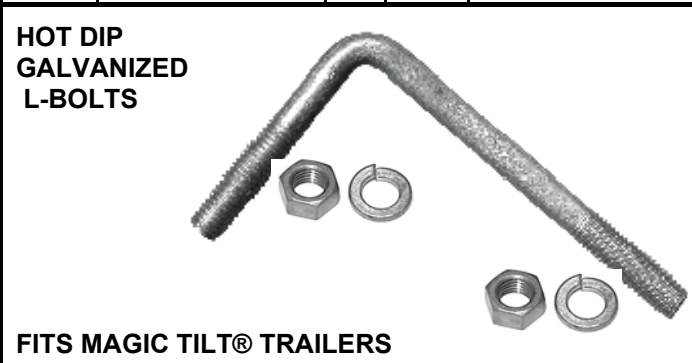

FITS MAGIC TILT® TRAILERS			
PART #	DESCRIPTION	WT	PRICE
0112	1/2" X 2 7/16" X 4 7/16"	.5#	\$2.49
0113	1/2" X 3 3/16" X 5 7/16"	.6#	\$2.69

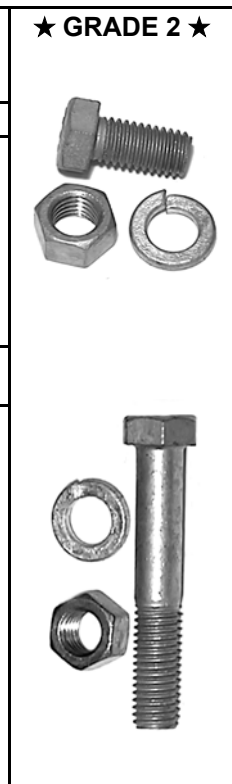

HOT DIP GALVANIZED BOX TUBE WINCH POST AND WINCH BASE

ARE SOLD SEPARATELY

ORDER ALL MOUNTING UBOLTS, BOLTS AND BOW TIE DOWN SEPARATELY

ALL WINCH POSTS FIT 3" WIDE TONGUE

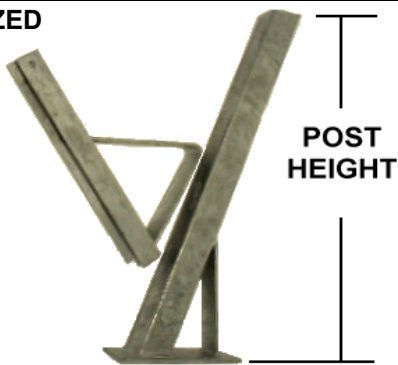

PART #	BOX TUBE	POST HEIGHT	BOW STOP HEIGHT	MAX WINCH	WT.	PRICE EA.
6021	2X3"	26"	30½"	1800#	17#	\$35.95
6022	3X4"	32"	41"	2600#	25#	\$48.95
6023	3X5" HVY	37"	45"	3200#	42#	\$69.95
6059	WINCH BASE FOR 2X3 POST - #6021				10#	\$18.95
4246	WINCH BASE FOR 3" WIDE POSTS				16#	\$29.95

FULTON® BOAT TRAILER WINCHES ZINC PLATED



PART #	CAPACITY	DESCRIPTION	WT	PRICE
4250	1300#	1 SPD ON/OFF	8#	\$24.95
1301	1800#	1 SPD FWD/REV	11#	\$36.95
1310	2000#	2 SPD FWD/REV	18#	\$59.95
1302	2600#	2 SPD FWD/REV	19#	\$69.95
3221	3200#	2 SPD FWD/REV	20#	\$89.95

WINCH STRAPS AND CABLES



PART #	BREAK STRENGTH	WT	PRICE
6024	2" X 20' X-HVY NYLON STRAP	10,000#	4# \$19.95
1305	2"X20' NYLON WINCH STRAP	3500#	1.6# \$9.95
3277	7/32 X 25' WINCH CABLE (ZINC PLT)	5600#	3.8# \$16.99
6060	1/4"X25' STAINLESS WINCH CABLE	6400#	5# \$29.95

PVC WINCH POST CAPS

PART #	DESCRIPTION	WT	PRICE
0237	2 X 2	.3#	\$1.98
0238	2 X 3	.4#	\$2.95
0239	2 X 4	.5#	\$3.95
0240	3 X 3	.5#	\$3.95
0241	3 X 4	.6#	\$4.95
0242	3 X 5	.7#	\$5.95



POLYURETHANE BOW STOPS

PART #	DESCRIPTION	WT	PRICE
4271	3" WIDE POLY BOW ROLLER ONLY	1.5#	\$7.95
4272	4" WIDE POLY BOW ROLLER ONLY	2#	\$8.95
RP434	3" WIDE POLY BOW ROLLER KIT W/END BELLS AND BOLT	3#	\$24.95
3229	4" WIDE POLY BOW ROLLER KIT W/END BELLS AND BOLT	4#	\$26.95
6026	POLY END BELLS ONLY (PR)	2.2#	\$15.95
RPV-2	2" POLY V BOW BLOCK	1.5#	\$8.95
4278	3" POLY V BOW BLOCK	2#	\$9.95
RP404	4" POLY V BOW BLK	3#	\$12.95

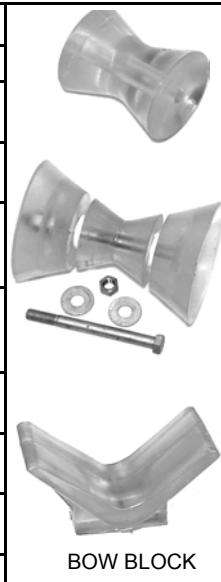

BOW BLOCK

BOW BLOCKS

GREY IS NON-MARKING

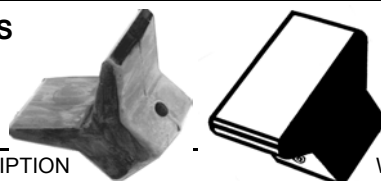

PART #	DESCRIPTION	WT	PRICE
0828	GREY RUBBER V BLOCK -3" WIDE BASE	2.7#	\$5.99
8228	GREY RUBBER V BLOCK -4" WIDE BASE	3#	\$6.99
0827	GREY RUBBER V BLOCK -2" WIDE BASE	2#	\$4.99
0829	BLACK FLAT BOAT BOW STOP- 3" BASE	2.7	\$4.99

FULTON® REPLACEMENT WINCH HANDLES W / NUT



PART #	DESCRIPTION	WT	PRICE
1306	6" REPLACEMENT WINCH HANDLE	1#	\$7.95
1307	7" REPLACEMENT WINCH HANDLE	1#	\$8.95
1308	8" REPLACEMENT WINCH HANDLE	1.5#	\$9.95
1304	10" REPLACEMENT WINCH HANDLE	2#	\$10.60
1311	NUT FOR WINCH HANDLE	.1#	\$0.59

2" X 4" BOX TUBE WINCH POST KIT

INCLUDES WINCH POST, WINCH BASE, PVC CAP AND UBOLTS TO MOUNT WINCH BASE TO WINCH POST.

DOES NOT INCLUDE 3" WIDE UBOLTS TO MOUNT WINCH POST TO TRAILER TONGUE.

REQUIRES 3 EACH 3" WIDE X ? UBOLTS TO ATTACH TO TONGUE (FITS 3" WIDE TONGUE)

MAXIMUM WINCH CAPACITY 2000#
WINCH POST VERTICAL HEIGHT 29 ½"
MAXIMUM BOAT BOW EYE ABOVE TRAILER TONGUE 35"
DOES NOT INCLUDE BOW ROLLER OR WINCH

PART # 0243
KIT WT 44#
KIT PRICE \$78.95



TURNBUCKLE - EYEBOLT BOW ANCHOR

TO PROPERLY SECURE YOUR BOAT TO YOUR TRAILER, USE A TURNBUCKLE AND ANCHOR BRACKET

NEVER USE YOUR WINCH STRAP OR CABLE AS YOUR ONLY BOW TIE DOWN DEVICE

BOW ANCHOR TIE DOWN BRACKET

FITS ON WINCH POST U-BOLT

PART #	DESCRIPTION	/T	PRICE
1494	FITS 2" WIDE TRAILER TONGUE	1#	\$4.95
1495	FITS 3" WIDE TRAILER TONGUE	1#	\$5.95

HI - QUALITY HOT DIP GALVANIZED DROP FORGED TURN BUCKLES

STYLE - HOOK AND EYE = HE
EYE TO EYE = EE

PART #	DIA. X TAKE UP	MAX CAP	STYLE	WT	PRICE
6068	3/8" X 6"	1000#	HE	1.2#	\$9.95
6069	3/8" X 6"	1000#	EE	1.2#	\$9.95
6070	1/2" X 6"	1500#	HE	2.3#	\$11.95
6071	1/2" X 6"	1500#	EE	2.3#	\$11.95

HOT DIP GALVANIZED DROP FORGED EYE BOLTS

PART #	BOLT SIZE	EYE SIZE	WT	PRICE
6103	3/8" X 2 1/2"	3/4"	.5#	\$2.95
6104	3/8" X 4"	3/4"	.7#	\$3.25
6105	3/8" X 6"	3/4"	.9#	\$3.59
6106	1/2" X 6"	1"	1.2#	\$4.95
6107	1/2" X 8"	1"	1.5#	\$5.49

HOT DIP GALVANIZED SCREW PIN ANCHOR SHACKLES

FORGED CARBON STEEL
HEAT-TREATED WITH ALLOY PINS
FED SPEC # RR-C271B CLASS I

PART #	SIZE	PIN DIA.	MAX CAP	WT	PRICE
6087	5/16"	3/8"	1500#	.3#	\$1.59
6088	3/8"	7/16"	2000#	.4#	\$1.95
6089	1/2"	5/8"	4000#	.5#	\$2.95

ZINC PLATED QUICK LINKS

PART #	SIZE	MAX CAP	WT	PRICE
6093	1/4"	1250#	.2#	\$0.99
6094	5/16"	1900#	.3#	\$1.49
6095	3/8"	2650#	.4#	\$2.39

GALVANIZED ANCHOR CHAIN

PART #	SIZE	TYPE	MAX CAP	WT /FT	PRICE /FT
6085	1/4-DIA	HOT DIP GALV PROOF COIL	1250#	1.2#	\$1.96
6086	5/16-DIA	HOT DIP GALV PROOF COIL	1900#	1.7#	\$2.95

PAIR OF HEAVY DUTY TRANSOM TIEDOWNS

MAXIMUM LENGTH 3 FT
2" WIDE

PART # 6013

WT 2.5#

PRICE/PAIR \$14.95

TIE DOWN ANCHOR POINT KIT

7/16" DIA ZINC BOLT 5/8" DIA EYE
1 1/4" LONG
INCLUDES LOCK WASHERS AND NUTS

PART # 10892 WT 1.5

PRICE PER PAIR \$5.95

RATCHET TIE DOWN STRAP

PART #	DESCRIPTION	WT	PRICE
1523	2" X 20' 10,000# RATCHET TIE DOWN	7#	\$27.99
1521	2" X 27' 10,000# RATCHET TIE DOWN	8#	\$29.99

NYLON GUNNEL TIE DOWN STRAP

PART #	DESCRIPTION	WT	PRICE
6014	2" X 13' GUNNEL TIE DOWN STRAP	2.5#	\$13.95
6012	2" X 16' GUNNEL TIE DOWN STRAP	2.5#	\$14.95
6011	2" X 20' GUNNEL TIE DOWN STRAP	3#	\$16.95

MOTO FLEX TRANSOM SAVER

* FOR USE WITH MOTORS UP TO 150 HP
* ADJUSTS FROM 20 1/2" TO 31"
* EDC FINISH FOR RUST RESISTANCE
* ROLLER MOUNT STYLE

PART # 6126

WT 7.5#

PRICE \$28.95

**BULLDOG® STYLE
A-FRAME COUPLERS**

FITS 50° FRAME
ANGLE
HAS JACK MOUNTING
HOLE



PART #	BALL SIZE	CAPACITY	WT	PRICE
4174	2"	7000#	17#	\$39.99
4175	2 5/16"	12,500#	20#	\$49.99

**STANDARD
A-FRAME
COUPLERS**



PART #	DESCRIPTION	WT	PRICE
F002	2" CLASS III 5000# A-FRAME COUPLER	11#	\$19.99
3176	2 5/16" CLASS IV 10,000# A-FRAME CPLR	13#	\$28.95

**ZINC PLATED
SAFETY CHAINS**



PART #	CLASS	DESCRIPTION	WT	PRICE
0722	II	3/16 X 21" W / ONE HOOK (PR)	4#	\$6.95/PR
0721	III	1/4 X 48" W / TWO HOOKS (EA)	5#	\$9.95/EA
0723	IV	5/16 X 52" W / TWO HOOKS (EA)	6#	\$12.95/EA

**FULTON®
GORILLA GUARD
COUPLER LOCKS**



PART #	BALL SIZE	WT	PRICE
3170	1 7/8"	3#	\$27.95
3171	2"	3.5#	\$28.95
3172	2 5/16"	4#	\$29.95

**BLACK VINYL JACKETED
AUTO RECOILING
SAFETY CABLES**



PART #	CLASS	CAP	WT	PRICE
59537	II	3500#	5#	\$11.95
59545	IV	7000#	7#	\$15.95

**FULTON® COUPLER
LATCH REPAIR KIT**

FITS FULTON® COUPLERS.
MAY NOT FIT OTHER BRANDS



PART #	COUPLER BALL SIZE	WT	PRICE
0717	FITS 1 7/8" OR 2" COUPLER	1#	\$9.95

**FULTON® STANDARD
TRAILER COUPLERS**



PART #	BALL	TONGUE	CLASS	CAP	WT	PRICE
F001	1 7/8"	2"	I	2000#	5#	\$12.95
0711	1 7/8"	2 1/2"	I	2000#	5#	\$12.95
0712	1 7/8"	3"	I	2000#	5#	\$12.95
0710	2"	2"	II	3500#	6#	\$16.95
0714	2"	2 1/2"	II	3500#	6#	\$16.95
0713	2"	3"	II	3500#	6	\$16.95
3169	2"	3"	III	5000#	7#	\$19.99

**WELD-ON 2 5/16" CLASS IV
20,000# TONGUE MOUNT
COUPLER**

3" WIDE TONGUE



PART # 0715
WT 12#
PRICE \$49.95

**BULLDOG® STYLE
STRAIGHT COUPLERS**

FIT 3" WIDE TONGUE



PART#	BALL SIZE	CAPACITY	WT	PRICE
3B4H	2"	7000#	13#	\$54.95
4B4H	2 5/16"	12,500#	16#	\$59.95

**FULTON® 2 PIECE
HEAVY COUPLER
SECURITY LOCK**

WITH 2 KEYS
PART # FU50
WT .5#
PRICE EACH \$6.95



**COUPLER LOCKING PIN
WITH SNAP RING**

PART # LS50
WT .2#
PRICE EACH \$1.99



**GRADE 5 COUPLER
MOUNTING BOLT / NUT**

PART # 4492
WT .5# 1/2" X 4 1/2"
PRICE EACH \$1.19



**HOT DIP GALVANIZED
BOX TUBE TONGUE
MATERIAL**

PART#	DESCRIPTION MAXIMUM 7' LONG FOR SHIPPING	WT/ FOOT	PRICE / FOOT
4177	1/8" X 3" X 3" GALVANIZED BOX TUBE	7#	\$6.70
7023	3/16" X 3" X 4" GALVANIZED BOX TUBE	9#	\$9.20



PART #	CAP	HOLE ID	DROP	RISE	LENGTH	TUBE SIZE	WT	PRICE
4182	6000#	1"	2"	3/4"	8 1/4"	1/4 X 2"	8#	\$16.95
4183	6000#	1"	4"	2"	8 1/4"	1/4 X 2"	9#	\$18.95
4184	6000#	1"	6"	4"	8 1/4"	1/4 X 2"	10#	\$24.95
4186	8,000#	1 1/4"	2"	3/4"	8 1/4"	SOLID	17#	\$45.95
4187	8,000#	1 1/4"	4"	2"	8 1/4"	SOLID	19#	\$49.95
4188	8,000#	1 1/4"	6"	4"	8 1/4"	SOLID	20#	\$55.95

2" BALL MOUNT HITCH BARS

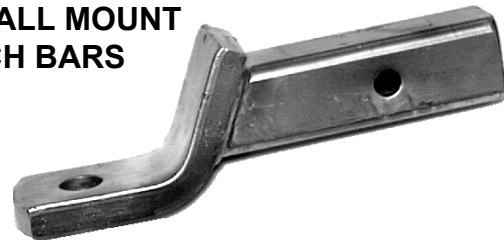

1 1/4" BALL MOUNT HITCH BAR

9 3/4" LONG

PART # D-19
WT 8#
PRICE EA \$21.95

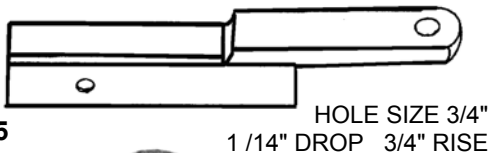

HOLE SIZE 3/4"
1 1/4" DROP 3/4" RISE



DUAL BALL MOUNT FOR 2" RECEIVERS

BALL SIZES 1 7/8" - 2"
3500# / 6000# CAPACITIES
8 1/2" SHANK LENGTH

PART # D-43 WT 11#

PRICE EA \$32.95

CHROME 3 WAY BALL MOUNT

BALL SIZES 1 7/8"-2"-2 5/16"
8,000# CAPACITY SOLID STEEL SHAFT

PART # 0133 WT 21# **PRICE EA**

\$49.95



RECEIVER TUBES FOR THE 2" X 2" BALL MOUNT

BUILD YOUR OWN CUSTOM RECEIVER HITCH

PART #	2 1/2" X 2 1/2" OD		PRICE EA
E11	12" RECEIVER TUBE	6#	\$16.95
E13	24" RECEIVER TUBE	10#	\$29.95
E14	36" RECEIVER TUBE	15#	\$39.95

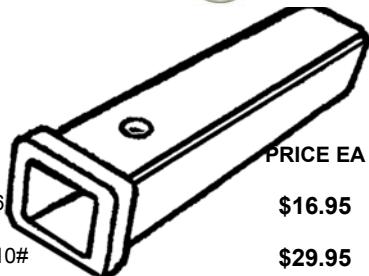

RECEIVER LOCKS

PART #	RECEIVER TUBE SIZE	WT	PRICE
3173	1 1/4 X 1 1/4"	2#	\$14.95
3174	2 X 2"	2#	\$14.95

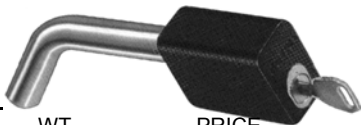

RECEIVER HITCH PINS

3237	1 1/4 X 1 1/4"	.2#	\$3.95
3238	2 X 2"	.2#	\$3.95
4282	SAFETY CLIP ONLY	.1#	\$0.95



CHROME DEADBOLT COUPLER LOCK

KCL-2	1/2" SPAN	2#	\$17.95
KCL-3	2" SPAN	2#	\$17.95

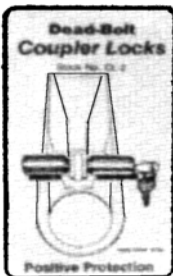

ZINC PLATED HEAT TREATED S - HOOKS

PART #	DIA	WGT	PRICE
J-26	3/8"	.3#	\$1.00
J-27	7/16"	.4#	\$1.99
J-28	9/16"	.5#	\$2.99



STANDARD CHROME HITCH BALLS

PART #	CAP	BALL SIZE	SHFT DIA	SHFT LGTH	WT	PRICE
4189	2000#	1 7/8"	3/4"	1 5/8"	2#	\$6.95
4190	3500#	1 7/8"	1"	2 1/8"	2.5#	\$7.95
4191	3500#	2"	3/4"	1 3/4"	2.5#	\$7.95
4192	5000#	2"	1"	2 1/8"	3#	\$8.95
4181	8000#	2"	1 1/4"	2 1/4"	3.5	\$29.95
4193	6000#	2 5/16"	1"	2 1/8"	3.5#	\$10.95
4194	10000#	2 5/16"	1 1/4"	2 1/4"	4#	\$11.95



STAINLESS STEEL HITCH BALLS

PART #	CAP	BALL SIZE	SHFT DIA	SHFT LGTH	WT	PRICE
A50	2000#	1 7/8"	3/4"	1 5/8"	2#	\$28.95
A51	3500#	1 7/8"	1"	2 1/8"	2.5#	\$31.95
A52	3500#	2"	3/4"	1 3/4"	2.5#	\$29.95
A53	6000#	2"	1"	2 1/8"	3#	\$32.95
A54	10000#	2 5/16"	1"	2 1/8"	3.5#	\$39.95



8" SHANK ADJUSTABLE PINTLE MOUNT 10,000# CAPACITY

WGT 15#
PART # E-23
PRICE \$34.95



15 TON REGULAR PINTLE HOOK

DROP FORGED WITH LYNCH STYLE SAFETY PIN

WGT 9#
PART # E-210

PRICE \$46.95



TO PLACE AN ORDER CALL 1-800-229-6690
OR FAX TO 1-800-359-8169
www.championtrailers.com

2002 - 2003 CHAMPION TRAILERS GALVANIZED TRAILERS

REQUIRED BOAT MEASUREMENTS TO DETERMINE WHICH TRAILER YOU WILL FIT YOUR NEEDS

- WEIGHT OF BOAT & MOTOR W/ FULL FUEL TANK • LENGTH OVERALL •
- STRAIGHT LENGTH OF BOAT FROM BOW EYE TO TRANSOM •
- WIDTH OF TRANSOM AT WATERLINE •

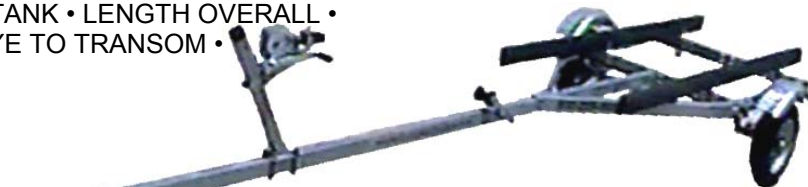

LITE DUTY JET SKI AND FLAT BOAT TRAILERS

FEATURES

- 3" LIGHT DUTY CHANNEL FRAME
- 1000# GVWR - 800# NET CAP
- (2) 2X4 BUNK BOARDS AND TONGUE ROLLER
- 1 7/8" COUPLER BALL SIZE
- 1200# LIGHT DUTY AXLE
- 1300# WINCH AND WINCH STRAP

OPTIONS

- TJ503 SWING JACK - \$34.95
- 2500# SPINDLE LUBE GALV AXLE - \$50.00
- 2" COUPLER BALL SIZE - \$20.00
- LIGHT DUTY PVC GUIDE POST KIT - \$29.95

TRAILER MO#	BOAT LENGTH	TIRE SIZE	WIDTH B/W FENDERS	WIDTH OVERALL	PRICE
PWC-1008	JET SKI - 10' MAX	480 X 8	43"	60"	\$440.00
PWC-1012	JET SKI - 10' MAX	480 X 12	43"	60"	\$480.00
F1214-1008	12 - 14'	480 X 8	43"	60"	\$450.00
F1214-1012	12 - 14'	480 X 12	43"	60"	\$490.00
F1416-1012	14 - 16'	480 X 12	52"	68"	\$525.00

BT1416-1500 HVY GALV FLAT BOAT TRAILER 14-16' BOAT 60"BTWN FENDERS • 1500# GVWR • 530X12 TIRE• 1235#NET CAP **\$735.00**

2500# GALV SPINDLE-LUBE® AXLE • 2" COUPLER • SWING JACK • 1300# WINCH W/ STRAP • (2) 2X4 BUNKS • ALL GALV HDWR

ALL GALVANIZED TRAILERS 2200# GVWR AND HIGHER INCLUDE:

- ★ GALVANIZED SPINDLE-LUBE® AXLES AND SPRING SUSPENSION SYSTEM
- ★ HOT DIP GALVANIZED CHANNEL FRAMES
- ★ 4 BUNK DRIVE-ON HULL SUPPORT SYSTEM
- ★ TREATED PINE LUMBER W/ HVY CARPET & SS STAPLES
- ★ GALV HARDWARE (BOLTS, UBOLTS, BRACKETS, ETC.)
- ★ HVY VINYL BOW ROLLER KIT (NON-MARKING)
- ★ SUBMERSIBLE LIGHT PACKAGE
- ★ GALVANIZED SPOKE RIMS
- ★ TONGUE JACK

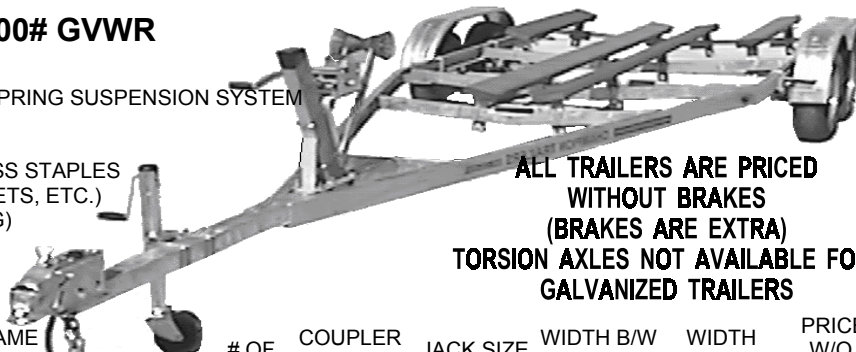

ALL TRAILERS ARE PRICED WITHOUT BRAKES (BRAKES ARE EXTRA) TORSION AXLES NOT AVAILABLE FOR GALVANIZED TRAILERS

MODEL NUMBER	BOAT LGNTH	GVWR	NET CAP	FRAME SIZE	TIRE SIZE	# OF AXLE	COUPLER SIZE	JACK SIZE	WIDTH B/W FENDERS	WIDTH OVERALL	PRICE W/O BRAKES
F1517-2264	15-17	2200#	1800#	3"	ST175/80D13C	1	2"	800#	64"	79"	\$840.00
SV1518-2564	15-18	2500#	1950#	4"	ST175/80D13C	1	2"	800#	64"	79"	\$996.00
SV1518-3564	15-18	3500#	2950#	4"	ST205/75D14C	1	2"	800#	64"	79"	\$1,045.00
SVW1518-3576	15-18	3500#	2850#	4"	ST205/75D14C	1	2"	800#	76" WIDE	92"	\$1,112.00
SV1619-3576	16-19	3500#	2850#	4"	ST205/75D14C	1	2"	800#	76"	92"	\$1,112.00
SVW1619-3584	16-19	3500#	2750#	4"	ST205/75D14C	1	2"	800#	84" WIDE	102"	\$1,155.00
TV1619-5076	16-19	5000#	4000#	4"	ST205/75D14C	2	2"	800#	76"	92"	\$1,615.00
TVW1619-5084	16-19	5000#	3900#	4"	ST205/75D14C	2	2"	800#	84" WIDE	102"	\$1,685.00
SV1720-3564	17-20	3500#	2850#	4"	ST205/75D14C	1	2"	800#	64"	79"	\$1,155.00
SV1720-5064	17-20	5000#	3850#	5"	ST225/75D15D	1	2"	800#	64"	79"	\$1,479.00
TV1720-5064	17-20	5000#	3750#	4"	ST205/75D14C	2	2"	800#	64"	79"	\$1,741.00
TV1720-7064	17-20	7000#	5900#	5"	ST225/75D15C	2	2 5/16"	1200#	64"	79"	\$1,988.00
SV1921-3500	19-21	3500#	2750#	4"	ST205/75D14C	1	2"	800#	84"	102"	\$1,155.00
SV1921-5000	19-21	5000#	4100#	5"	ST225/75D15D	1	2"	800#	84"	102"	\$1,480.00
TV1921-5000	19-21	5000#	3900#	4"	ST205/75D14C	2	2"	800#	84"	102"	\$1,742.00
TV1921-7000	19-21	7000#	5800#	5"	ST225/75D15C	2	2 5/16"	1200#	84"	102"	\$1,990.00
TV2022-5000	20-22	5000#	3700#	4"	ST205/75D14C	2	2"	800#	84"	102"	\$1,805.00
TV2022-7000	20-22	7000#	5600#	5"	ST225/75D15C	2	2 5/16"	1200#	84"	102"	\$2,040.00
TV2224-7000	22-24	7000#	5500#	5"	ST225/75D15C	2	2 5/16"	2000#	84"	102"	\$2,085.00
TV2224-10000	22-24	10000#	8200#	6"	ST225/75D15D	2	2 5/16"	2000#	84"	102"	\$2,485.00
TV2426-7000	24-26	7000#	5300#	5"	ST225/75D15C	2	2 5/16"	2000#	84"	102"	\$2,135.00
TV2426-10000	24-26	10000#	8100#	6"	ST225/75D15D	2	2 5/16"	2000#	84"	102"	\$2,590.00
TTV2426-15000	24-26	15000#	13000#	6"	ST225/75D15D	3	2 5/16"	2000#	84"	102"	\$3,075.00
TV2628-10000	26-28	10000#	8000#	6"	ST225/75D15D	2	2 5/16"	2000#	84"	102"	\$2,888.00
TTV2628-15000	26-28	15000#	12800#	6"	ST225/75D15D	3	2 5/16"	2000#	84"	102"	\$3,500.00
TV2931-10000	29-31	10000#	7900#	6"	ST225/75D15D	2	2 5/16"	2000#	84"	102"	\$3,185.00
TTV2931-15000	29-31	15000#	12700#	6"	ST225/75D15D	3	2 5/16"	2000#	84"	102"	\$3,930.00

ALL TRAILERS ARE PICKED UP FROM OUR SLIDELL I-10 LOCATION. DELIVERY IS NOT AVAILABLE!! MAKE SURE YOUR TOW VEHICLE IS TRAILER READY WHEN COMING TO PICK UP YOUR NEW TRAILER! THERE WILL BE A \$10.00 CHARGE TO CHANGE COUPLER BALL ON TOW VEHICLE. NO EXCEPTIONS!!

2002 - 2003 CHAMPION ALUMINUM TRAILERS

WITH STAINLESS UBOLTS AND TORSION AXLES

STANDARD FEATURES



- ALUMINUM I-BEAM FRAME WITH ALUMINUM CROSSMEMBERS
- GALVANIZED TORSION AXLES W/REPLACEABLE SPINDLES
- DRIVE-ON HULL SUPPORTS W/ TREATED PINE BUNKS
- SUBMERSIBLE LIGHTS • POLY BOW ROLLER
- ALUMINUM FENDERS • GALV SPOKE RIMS
- WINCH AND STRAP • TONGUE JACK

OPTIONAL UPGRADES

- **UGLED** LED LIGHT PACKAGE \$189.95
- **UG80WF** UPGRADE TO 80" WIDE FRAME \$150.00
- **PVCALUM** PVC SIDE GUIDES WITH STAINLESS HDWR \$59.95
- **RP8KIT** - 8" POLY KEEL ROLLER W/ SS PIN \$40.00 PER CROSSMEMBER
- **STC** - SPARE TIRE CARRIER FOR ALUM TRAILER (PLAIN - NO HUB) \$59.00
- **UGALUMRIM** - WITH SS LUG NUTS 14" - \$60.00 15" - \$70.00 PER WHEEL

SEE BRAKE OPTIONS PRICE CHART BELOW

TRAILERS W/5200# AXLES HAVE SPRING SUSPENSION

MODEL NUMBER	BOAT LENGTH	GVWR	NET CAP	FRAME SIZE	TIRE SIZE	# OF AXLE	COUPLER SIZE	JACK SIZE	WIDTH B/W FENDERS	WIDTH OVERALL	PRICE WITHOUT BRAKES
SA1517-2560	15-17	2500#	2000#	3 X 4 1/2	ST17580D13C	1	2	800#	60"	81"	\$1,299
SA1517-3560	15-17	3500#	2700#	3 X 4 1/2	ST20575D14C	1	2	800#	60"	81"	\$1,329
SA1517-3574	15-17	3500#	2670#	3 X 4 1/2	ST20575D14C	1	2	800#	74"	93"	\$1,389
SA1719-3574	17-19	3500#	2610#	3 X 4 1/2	ST20575D14C	1	2	800#	74"	93"	\$1,438
SA1719-5074	17-19	5000#	4300#	3 X 5 1/2	ST22575D15D	1	2	800#	74"	93"	\$1,936
TA1719-5074	17-19	5000#	4100#	3 X 5 1/2	ST20575D14C	2	2	800#	74"	93"	\$2,089
SA1921-3574	19-21	3500#	2520#	3 X 4 1/2	ST20575D14C	1	2	800#	74"	93"	\$1,543
SA1921-5074	19-21	5000#	4100#	3 X 5 1/2	ST22575D15D	1	2	800#	74"	93"	\$1,966
TA1921-5074	19-21	5000#	4000#	3 X 5 1/2	ST20575D14C	2	2	1200#	74"	93"	\$2,141
TA2224-5074	22-24	5000#	3950#	3 X 5 1/2	ST20575D14C	2	2	1200#	74"	93"	\$2,254
TA2224-7074	22-24	7000#	5950#	4 X 6 1/2	ST22575D15C	2	2 5/16	1200#	74"	93"	\$2,464
TA2224-8674	22-24	8600#	7440#	4 X 6 1/2	ST22575D15D	2	2 5/16	2000#	74"	93"	\$2,574
TA2426-7074	24-26	7000#	5785#	4 X 6 1/2	ST22575D15C	2	2 5/16	1200#	74"	93"	\$2,539
TA2426-8674	24-26	8600#	7250#	4 X 6 1/2	ST22575D15D	2	2 5/16	2000#	74"	93"	\$2,698
TA2426-9874	24-26	9800#	8350#	4 X 7 1/2	ST22575D15D	2	2 5/16	2000#	74"	93"	\$2,891
TTA2426-10074	24-26	10000#	8480#	4 X 7 1/2	ST20575D14C	3	2 5/16	7000#	74"	93"	\$3,291
TTA2426-12074	24-26	12000#	10455#	4 X 7 1/2	ST22575D15D	3	2 5/16	7000#	74"	93"	\$4,145
TA2628-9874	26-28	9800#	8250#	4 X 7 1/2	ST22575D15D	2	2 5/16	2000#	74"	93"	\$2,984
TTA2628-10074	26-28	10000#	8600#	4 X 7 1/2	ST20575D14C	3	2 5/16	7000#	74"	93"	\$3,394
TTA2628-12074	26-28	12000#	10344#	4 X 7 1/2	ST22575D15D	3	2 5/16	7000#	74"	93"	\$4,325
TA2931-9874	29-31	9800#	8150#	4 X 7 1/2	ST22575D15D	2	2 5/16	2000#	74"	93"	\$3,186
TTA2931-12074	29-31	12000#	10244#	4 X 7 1/2	ST22575D15D	3	2 5/16	7000#	74"	93"	\$4,604

BRAKE OPTIONS- WARNING LOUISIANA LAW REQUIRES BRAKES ON ALL TRAILERS GROSSING 3000# AND UP [5000# AND UP REQUIRE BRAKES ON ALL AXLES] ANY ONE PURCHASING A TRAILER IN THESE CATEGORIES WITHOUT BRAKES ASSUMES ALL LIABILITIES RESULTING FROM THIS CONDITION AND MUST SIGN A LIABILITY WAIVER.

STAINLESS STEEL DISC BRAKE			GALVANIZED DRUM BRAKE			GALVANIZED ELECTRIC BRAKE		
DB651	6000# 5 LUG 1 AXLE	\$399	GB6101	6000# 10" 1 AXLE	\$389	GEB101	10" GALV ELEC 1 AXLE	\$279
DB652	6000# 5 LUG 2 AXLES	\$650	GB6102	6000# 10" 2 AXLES	\$640	GEB102	10" GALV ELEC 2 AXLES	\$485
DB751	7500# 5 LUG 1 AXLE	\$550	GB75101	7500# 10" 1 AXLE	\$530	GEB121	12" GALV ELEC 1 AXLE	\$360
DB752	7500# 5 LIG 2 AXLES	\$800	GB75102	7500# 10" 2 AXLES	\$780	GEB122	12" GALV ELEC 2 AXLES	\$620
DB1061	10000# 6 LUG 1 AXLE	\$705	GB10121	10000# 12" 1 AXLE	\$685	NOW AVAILABLE TURBO LUBE® HUB UPGRADE FOR CERTAIN TRAILERS SEE SALES REP FOR PRICING AND AVAILABILITY		
DB1062	10000# 6 LUG 2 AXLES	\$1025	GB10122	10000# 12" 2 AXLES	\$1030			
DB1063	10000# 6 LUG 3 AXLES	\$1340	GB12123	10000# 12" 3 AXLES	\$1375			
DB2062	20000# 6 LUG 2 AXLES	\$1075	GB20122	20000# 12" 2 AXLES	\$1080			
DB2063	20000# 6 LUG 3 AXLES	\$1385	GB20123	20000# 12" 3 AXLES	\$1425			

CHAMPION TRAILERS WILL SET YOUR TRAILER TO FIT YOUR BOAT! BOAT ADJUSTMENTS REQUIRE THAT YOU DROP YOUR BOAT OFF AND LEAVE IT. YOU MUST HAVE AN APPOINTMENT ON OUR WORK SCHEDULE TO HAVE THE ADJUSTMENT DONE. IF THE BOAT IS IN THE YARD AT THE TIME THE TRAILER IS BEING BUILT, THE ADJUST CAN BE DONE DURING THE SAME APPOINTMENT.

BOAT LENGHTH	LABOR HOURS	PRICE	BOAT LENGHTH	LABOR HOURS	PRICE	BOAT LENGTH	LABOR HOURS	PRICE
0-20'	2 HRS	\$90.00	21-24	3 HRS	\$135.00	25-31	4 HRS	\$180.00

ALL TRAILER SALES WILL HAVE A \$13.00 NOTARY FEE ADDED TO THE INVOICE TOTAL

STAINLESS ROTOR DISC BRAKE KITS

FEATURING

- ▶ TIE DOWN ENGINEERING®
- ▶ FITS 5 LUG 13"-14"-15" 545 RIM
- ▶ BOLT PATTERN 5 ON 4.5"
- ▶ STAINLESS DISC BRAKES
- ▶ WITH ALUMINUM CALIPERS
- ▶ TIEDOWN* SURGE BRAKE COUPLER
- ▶ STAINLESS STEEL BRAKELINE TUBING KIT
- ▶ BLEED SOLENOID VALVE

NOTE: 5 LUG SS DISC BRAKES USE BEARINGS 68149 INNER AND 44649 OUTER AND HAVE A 5 LUG ON 4.5 (545) BOLT PATTERN (SEE PAGE # 4 - HOW TO MEASURE A 5 BOLT HUB)

TANDEM AXLE BRAKE KIT

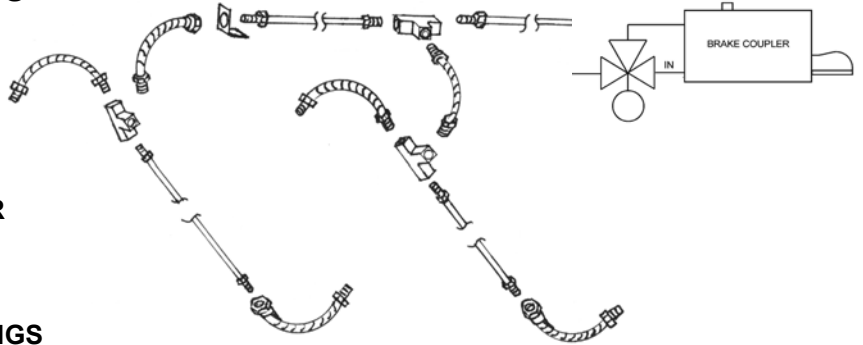

WARNING!!

DO NOT CUT STAINLESS TUBING. USE FACTORY COMPLETE PIECES ONLY.

PART #0149DB DISC BRAKES KIT:

BRAKE KIT INCLUDES		
QTY	PART #	
1	0143DB	DISC BRAKE COUPLER
2	3287	5 LUG 545 SS DISC BRAKE UNITS

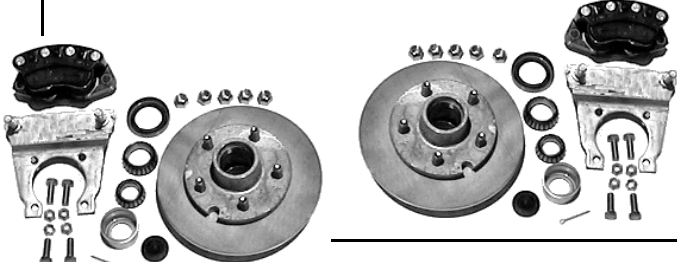

SINGLE AXLE BRAKE KIT

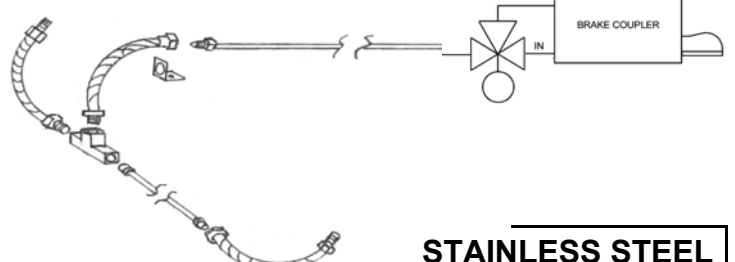

STAINLESS STEEL SINGLE AXLE DISC BRAKE TUBE KIT

STAINLESS STEEL BRAKE LINE TUBING KIT FOR ONE AXLE WITH 16' MAINLINE,

1	1504	REVERSING SOLENOID
---	------	--------------------

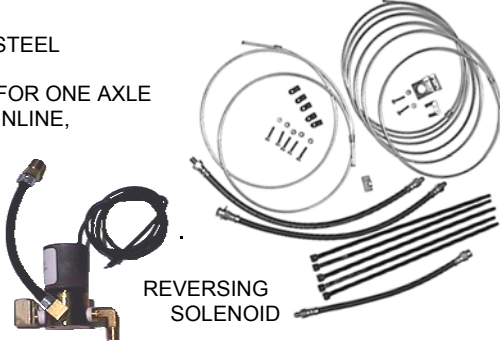

PART #	DESCRIPTION	Wt	PRICE PER KIT
DBSS16	KIT WITH 16' MAINLINE	6#	\$98.70
DBSS20	KIT WITH 20' MAINLINE	7#	\$108.90
DBSS23	KIT WITH 23' MAINLINE	8#	\$116.90

QTY	PART #	DESCRIPTION
1	3087	60" - 5' SS TUBING
1	0520	13" MALE/FEMALE HOSE
1	0521	18" MALE/MALE HOSE
1	6108	18" MALE/FEMALE BRAKE HOSE
1	0516	BRASS TEE
1	3118	ANGLE CLIP
5	4011	1 HOLE STRAP & SCREWS
6	3091	NYLON TYRAPS

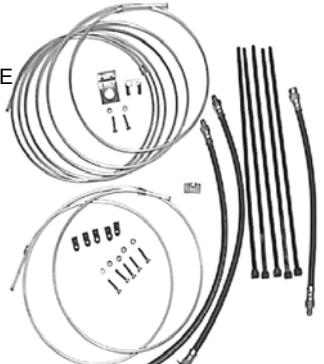

WGT 73# **PART # 0149DB KIT PRICE \$399.99**

2ND AXLE DISC BRAKE KIT



PART # 3294 KIT INCLUDES	
PART # 3287	2 - 5 LUG # 545 SS DISC BRAKE UNITS
PART #DBSS2	2 ND AXLE STAINLESS BRAKE TUBE KIT
WGT 50 #	2ND AXLE DISC BRAKE KIT PRICE \$249.99

2ND AXLE STAINLESS STEEL DISC BRAKE TUBING KIT

QTY	PART #	DESCRIPTION	PRICE PER KIT
2	0521	18" MALE/MALE HOSE	PART # DBSS2 KIT PRICE \$57.50 WGT 4#
2	0516	BRASS TEE	
1	0520	18" MALE/FEMALE HOSE	3'
1	3087	60" - 5' SS TUBING	
1	3085	36" - 3' SS TUBING	5'
5	3091	NYLON TYRAPS	
2	4011	1 HOLES STRAP & SCREWS	

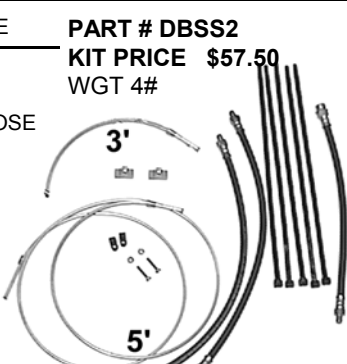

TIE DOWN ENGINEERING® DISC BRAKE COMPONENTS

TIE DOWN ENGINEERING®
5 LUG STAINLESS DISC BRAKES
 (5 LUG ON 4.5" BOLT PATTERN ONLY) INCLUDES HUB/ROTOR (WITH BEARINGS # 68149 AND 44649) CALIPER AND GALV ADAPTER PLATE.
PART # 3287 5 LUG



TWO BRAKE UNITS REQUIRED PER AXLE

PRICE PER WHEEL \$98.99 WGT 23#

TIE DOWN ENGINEERING®
6 LUG STAINLESS DISC BRAKES
 INCLUDES HUB/ROTOR (WITH BEARINGS #25580 AND 15123) CALIPER AND ADAPTER PLATE
 6 ON 5 1/2" BOLT PATTERN
PART # 3288 6 LUG



TWO BRAKE UNITS REQUIRED PER AXLE

PRICE PER WHEEL \$129.80 WGT 28#

REPLACEMENT 5 LUG HUB ROTOR WITH BEARINGS
PART# 0134
 WGT 20#



PRICE EA \$63.95

REPLACEMENT 6 LUG HUB ROTOR WITH BEARINGS
PART# 0137
 WT 25#



PRICE EA \$89.95

5 LUG ADAPTER PLATE
PART# 0135
 WT 4#



PRICE EA \$11.95

6 LUG ADAPTER PLATE WITH SHIM BLOCK
PART# 0136
 WT 5#



PRICE EA \$14.95

BLOCKING SOLENOID VALVE
 12 VDC SOLENOID VALVE CONNECTS VIA PLUG TO THE TOW VEHICLE BACK UP LIGHTS FOR AUTOMATIC BRAKE LOCKOUT. (IF BRAKES ARE LOCK WHEN BACKING UP - PULL FORWARD ABOUT 1 FOOT AND PUT TOW VEHICLE INTO REVERSE.)
PART # 1507
 WGT .5#
PRICE EA \$34.95



TIEDOWN* 6600# BRAKE COUPLER
 MODIFIED FOR USE WITH DISC BRAKES
PART # 0143DB
 WGT 27#

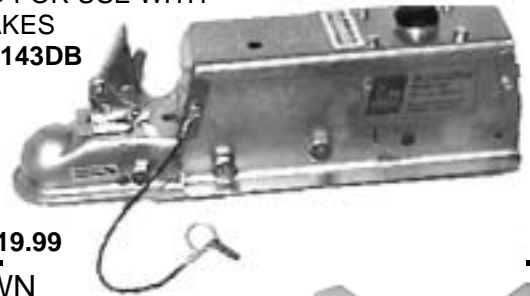

PRICE \$119.99

TIE DOWN ENGINEERING®
REPLACEMENT DISC BRAKE PADS
 WGT PER PAIR .5#



PART # 3298 B PRICE EA PAIR \$13.95
 TWO PAIR REQUIRED PER AXLE

TIE DOWN ENGINEERING®
DISC BRAKE CALIPER BLEED VALVES



PART #	TYPE	WT .1	PRICE EA
3282	BV-2 ONE PIECE ALL BRASS STRAIGHT THREAD		\$3.95

REPLACEMENT STAINLESS ROTORS AND WHEEL STUDS FOR TIE DOWN® DISC BRAKES

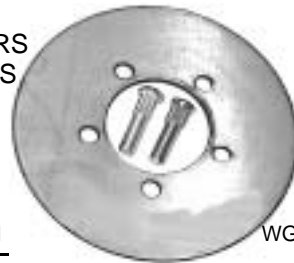

PART #	DESCRIPTION	WGT	PRICE EA
3283	5 LUG ROTOR ONLY	6#	\$39.95
3284	6 LUG ROTOR ONLY	7#	\$43.95
3285	STUD FOR 5 LUG SS DISC BRAKE	.1#	\$1.95
3286	STUD FOR 6 LUG SS DISC BRAKE	.1#	\$1.95

TIEDOWN ENGINEERING®
REPLACEMENT CALIPER
 WITH BRONZE BUSHINGS. FITS ALL TIEDOWN ENGINEERING UNITS MFG AFTER 3/1/99



PART #3289
 WGT 5#
PRICE EA \$66.80

BLEED SOLENOID VALVE KIT

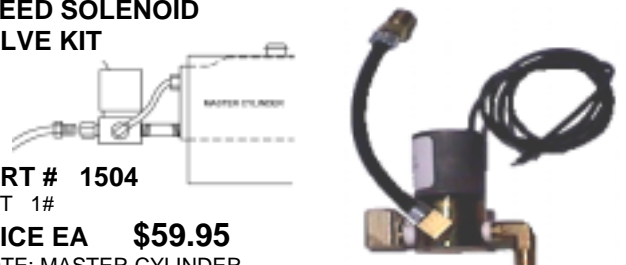

PART # 1504
 WGT 1#
PRICE EA \$59.95
 NOTE: MASTER CYLINDER NOT INCLUDED

Part # 0149DB DISC BRAKE KIT INSTALLATION with the Tiedown Model 66 -6600#

Disc Brake Coupler

[1] To begin the installation, it requires that your axle be compatible with the components of the brake kit. This first requires that your axle spindles use bearing # **68149 (1 3/8")** inner bearing next to the seal and bearing number # **44649 (1 1/16")** outer bearing next to the spindle nut. Your axle must also have a **4-hole brake flange** in place.

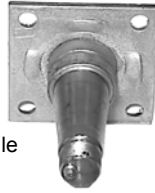

If your axle has these features you can proceed with the installation. If it does not, you will need to purchase an axle to match these system requirements. [see pages 2 and 3 of the *CHAMPION TRAILERS PARTS CATALOG*, For axle order information .)

With a spring suspension system, when only one brake axle is being installed on a tandem axle trailer, it is advisable to have brakes on the rear axle for maximum system performance. Rotational torque applied to axles during braking shifts the equalizer of a spring suspension system and applies more weight to the rear axle allowing the rear tires to dig into the road. If brakes are installed on the front axle, the wheels may skid during braking.

[2] BRAKE COUPLER INSTALLATION

The Part # 0149DB disc brake kit is supplied with a Tiedown Model 66DB [6600#] max cap] disc brake coupler, and a reversing solenoid valve.

Note: this coupler is designed for use with disc brakes and must not be used with drum brakes!

Disc brakes provide 100% braking in both forward and reverse directions, whereas drum brakes lose most of their braking ability when backing up. Therefore a method of disabling the trailer disc brakes, during reverse direction operation, is required. This brake kit is supplied with a reversing solenoid valve.

This valve is connected to the back up light on the tow vehicle via a plug which is supplied with the kit. When the tow vehicle is put into

reverse , the back up lite comes on which then activates the reversing solenoid valve , and disables the trailer brakes while backing up .

If your existing idler (non-braking coupler) is bolted on and has the standard 3" centerline mounting bolt holes, you should be able to remove the old idler coupler and reinstall the new Tiedown brake coupler with the mounting bolts supplied with this kit. If your old coupler is welded on or has non standard bolt hole placement, you will need to remove the existing coupler and drill new holes.

[3] HUB ROTOR INSTALLATION

You should have previously confirmed your axle bearing and brake flange compatibility with the components of this kit. Now you are ready to remove the existing idler hubs from the axle. **Be sure to retain the spindle washer and spindle nut for reuse with the disc brake installation.** They are not supplied with the brake kit and may have parameters that make them unique to your spindles. At this point pre-pack your bearings and install them and your seals into the hub rotor units. **Be sure that you fully pack the bearings before installation, and be sure to use high temp grease. Disc brakes will run hotter than either idler hubs or drum brakes.**

[4] PRE-LOADING THE BEARINGS

Whether installing idler hubs, drum brakes , or disc brakes it is essential that you pre-load the bearings during hub installation. To properly pre-load your bearings proceed as follows.

After pre-packing your bearings with grease and installing the rear bearing and seal into your hub rotor, slide the hub-rotor onto the spindle and install the outer bearing , thrust washer, and spindle nut. Now tighten the spindle nut **UNTIL IT BECOMES SNUG** and then about a ¼ turn, or about 10 ft. pounds of torque more. Rotate the hub rotor by hand about 10 revolutions. At this point back off of the spindle nut until it is very loose, and re-tighten finger tight while turning the hub in the direction that the nut is turning while tightening. When you feel the snug point again, install the cotter pin, tab washer or other nut retaining device. **WARNING - DO NOT OVER-TIGHTEN THE SPINDLE**

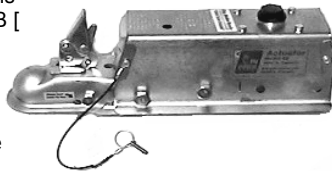

NUT. TO DO SO MAY RESULT IN FAILURE OF THE BEARINGS.

[5] INSTALLING THE CALIPERS

The caliper head slides onto the 2 EA - ½" stainless pins in the galvanized brake flange adapter plate. The caliper head floats on these two stainless pins. Be sure that the caliper slides easily onto these pins , and lubricate the SS pins with grease before assembly . With the caliper on the pins of the adapter plate, slide the caliper onto the top edge of the stainless rotor. This should allow the adapter plate to have it's holes line up with the four holes in the brake flange welded to the 3500# axle.



The galvanized adapter plate attaches to the front (spindle) side of the brake flange on the axle. You can now install the 4 ea 7/16" x 1" stainless bolts to attach the adapter plate to the brake flange. Torque to 25 ft pounds.

[Note] these installation instructions are intended for the 5 lug - 3500# disc brake units with 4 hole brake flanges . If you are installing 6 lug - 5200# disc brake units , the adapter plate has 3-3/8" holes and it also has a galv spacer plate that installs between the adapter plate and the front of the brake flange on the axle. [on the 5200# axle the brake flange has 5 - 3/8" holes . With the Tiedown disc brake units for this axle only the top three holes are used to attach the adapter plate , and spacer.

Brake flanges on many axles **may not** be square with the spindle shaft and may require shimming the galvanized adapter plate to align the caliper head with the rotor. To test for alignment, now that you have the adapter plate securely bolted to the brake flange, rotate the hub/rotor. The hub/rotor should turn with only a moderate amount of dragging between caliper pads and rotor. If the rotor is hard to turn or is locked up and will not turn, the brake flange is probably out of square with the spindle.

Visually observe whether the edge of the rotor and the calipers are out of alignment. If brake flange mis-alignment is evident, loosen one or more of the nuts holding the adapter plate to the brake flange until you can hold the caliper head in a linear relationship to the rotor. Where necessary, install thin 7/16" stainless flat washers between the brake flange and adapter plate .These shim washers are not supplied as part of this kit. If it is necessary to remove the stainless nylon self-locking nuts from the flange mounting bolts, you should replace them. **Nylon self lock nuts are intended for one use only.** The hub/rotor should now turn easily with only moderate pad to rotor drag.

The calipers are normally positioned nearly vertical at the **12:00 o'clock position**, however they will work in any position. The vertical 12:00 o'clock position is best for brake bleeding, giving the best opportunity to totally purge all air from the system. NOTE: Any air trapped in the system will **radically decrease braking performance.**

[6] BRAKE TUBING INSTALLATION

The brake tube kit supplied with this disc brake package can be used with either torsion or spring suspension axles.

The standard stainless brake line tubing kit includes one each 16' mainline tubing. This tubing is routed from the brake coupler back to the brake axle, down one side of the trailer. If your trailer requires more than a 16' main line, you can order an additional coupler nut (Part # 0517) and an additional length of stainless brake tubing. (Not included in kit price.) Near the point where the brake axle crosses the frame, install the hose mounting angle bracket. Attach the female side of the 13" male/female hose to the bracket with the u-shaped hose spring clip.

Attach the mainline tubing to the female side of the hose and install the brass tee to the male end of the brake hose. This provides a flexible connection from the trailer frame down to the axle.

The 18" male/male hose goes from the tee to the near side caliper. The 5' tube goes across the axle and the 18" male/female connects to it and the far side caliper. The brake tubing is now strapped to the axle using the black 14" tyrap included with the kit. Be sure to route the flex hoses so that they are not rubbing against the trailer frame during highway travel .

WARNING: DO NOT CUT THE STAINLESS TUBING. USE FACTORY COMPLETE PIECES ONLY!! US - DOT regulations require double flare on brake line tubing. This cannot be accomplished without special tooling on the stainless tubing. Before bleeding the system, check that all brake line tubing connections are tight.



[7] BLEEDING THE BRAKES

The Tie Down Engineering® disc brakes included in this kit have dual pistons with two bleed valves per caliper. It is important to ***OPEN ONLY ONE BLEED VALVE AT A TIME*** during the brake bleeding process. Begin bleeding the brakes by opening one bleed valve on the caliper closest to the master cylinder in the tubing sequence. On tandem brake axle installations, bleed the brakes on the front axle first.

Before attempting to bleed the brakes it will be necessary to pre-bleed the master cylinder. First remove the brake line tubing from the brass tubing adapter at the rear of the master cylinder reversing solenoid. Now hold your finger tightly over the hole in the rear of the brass tubing adapter. After filling the master cylinder reservoir with clean DOT 3 brake fluid, begin pumping the master cylinder.

To pump the master cylinder on the Tiedown brake coupler insert a screw driver into the hole on top of the coupler and pull forward and backward. Air bubbles will purge thru the holes on the bottom of the master cylinder reservoir as you pump the master cylinder. After several strokes you will feel pressure building up on your finger at the rear of the cylinder. Occasionally while pumping, release pressure and let air escape past your finger. Eventually a fountain of fluid will erupt from the holes in the bottom of the cylinder reservoir. This affirms that the master cylinder is now primed and ready to bleed the brakes. Reconnect the brake tubing and proceed to bleed the brakes.

BE CAREFUL NOT TO LET THE MASTER CYLINDER RESERVOIR RUN DRY DURING THE BLEEDING PROCESS. Every three or four strokes, refill the reservoir. If air is sucked into the master cylinder, you must begin the bleeding process anew.

Install a clear plastic hose onto the bleed valve and insert the loose end of the hose into a clear container partially filled with brake fluid to observe air bubbles. It is best to have this fluid receiving container at an elevation above the caliper during the bleeding procedure. For best results during bleeding, pinch the bleed hose, or close the bleed valve on the return stroke.

Pump fluid through the system until no bubbles are present. Close the bleed valve on this piston and repeat the process on the second piston. When completed with the first caliper, repeat the process on the next caliper. **Brake fluid is toxic. Dispose of the containers and used fluid properly.**

(NOTICE) Disc brakes require high static line pressure for effective braking performance. Any air trapped in the system will drastically reduce braking performance. Proper brake bleeding is the best way to assure good system performance.

[**ALSO**] because disc brakes require high static line pressure for optimum system performance, if you use non steel brake line tubing [all flexible hose] for your brake line tubing, you may have lower static system line pressure and this may reduce the overall system braking results. It is strongly recommended that DOT approved steel or stainless steel brake line tubing be used and that flex hoses be kept to a minimum.

[8] TESTING THE BRAKES

Re-install the tires back onto the hub/rotors and have an associate rotate the wheel rapidly. While this is being done, apply firm, aggressive pressure to the manual pump lever screwdriver, that you used to pump the brakes during the brake bleeding procedure. The wheel should come to an abrupt stop. Now release pressure on the screwdriver and pull the brake coupler to it's fully telescoped [towing] position.

The wheel should now turn with only a moderate dragging of the pads.

THIS COMPLETES THE INSTALLATION OF YOUR DISC BRAKE SYSTEM

Standard DISC BRAKE System TROUBLE SHOOTING

▶ MY BRAKES ARE OVER HEATING

Disc brakes normally run hotter than drum brakes due to partial contact of pad and rotor during normal highway travel; whereas drum brakes have a return spring that retracts the brake shoes with virtually no contact between the shoes and drum.

Your disc brakes during normal highway travel should be "very warm", but still allow you to put your hands on the hub without burning. However during frequent braking periods, such as stop and go braking, they may be too hot to touch.

NOTE: IF BRAKE HEATING IS EXCESSIVE, CHECK THAT THE HOLE IN THE BRASS BRAKE LINE TUBING ADAPTER IS NOT OBSTRUCTED.

Also be sure that the master cylinder tubing adapter orifice is bored to a minimum of .030". This will facilitate the return flow of fluid to

the master cylinder on the return stroke.

▶ MY HUBS ARE SLINGING EXCESSIVE AMOUNTS OF GREASE**

Since disc brakes run hot, it is important to use a high Temperature grease specifically intended for disc brakes. Other greases may lose their viscosity at higher temperatures and liquify, allowing them to sling out past the seal or dust cap. CHECK FOR WORN SEALS. In most installations it will be necessary to install SPINDLE-LUBE dust caps and bellows plugs, to allow the grease to expand during high temperature operation.

▶ MY DISC BRAKES DON'T GIVE EFFECTIVE BRAKING

[1] Air bubbles may be present in the system.

SOLUTION: Re-bleed brakes.

*Also check fluid level in the master cylinder.

[2] Corroded master cylinder walls not allowing high pressure to build up on the power stroke.

SOLUTION: Replace or rebuild master cylinder.

[3] Inadequate number of brake units for the load being towed.

SOLUTION: If load being towed is over **3000# gwvr**, **put brakes on all axles.**

[4] If you have an all flex hose brake line tubing installation you may need to change to a steel brake tubing system. As static line pressure increases in flexible tubing it swells up in response to the increase in pressure. This decreases the overall system line pressure and can result in reduced brake system performance, especially when used with disc brake systems, and their higher line pressure requirements.

▶ MY BRAKES LOCK UP WHEN BACKING UP

* Disc brakes give 100% braking either forward or backward. On most disc brake systems, a reversing solenoid valve is installed.

* If your reversing solenoid is not operating properly, check for proper ground connection on both trailer and tow vehicle. Also check that at least 10VDC is available at the (+) positive lead going to the solenoid.

* To test the electrical operation, have an assistant put the tow vehicle into and out of reverse, confirming that the back up lights on the tow vehicle come on when **and only when** the tow vehicle is in reverse. You should hear or feel a discernable click as the valve cycles. NOTE: IF THE (WHITE) BACKUP LIGHTS COME ON IN ANY GEAR OTHER THAN REVERSE, THE BRAKES WILL BE DISABLED IN THAT CONDITION!! **This could disable the brakes during normal highway travel.**

* NOTE : the Tiedown disc brake coupler is equipped with an emergency brake lock out pin. You can use it to lock out brakes when backing up, **HOWEVER** it should only be used as an emergency device.

ALWAYS REMOVE THE PIN WHEN TRAVELING FORWARD, OR the BRAKES WILL BE DISABLED !!!!

WARNING: WHEN REPLACING DRUM BRAKES WITH DISC BRAKES, and using your preexisting SURGE BRAKE COUPLER, the brake coupler WILL REQUIRE MODIFICATION.

If you are replacing drum brakes with disc brakes on a trailer, and are using your existing surge brake coupler, there are some modifications that will be required of the brake coupler for successful operation with disc brakes.

[A] first it will be necessary to remove or puncture your residual valve in the master cylinder. **WARNING** attempting to puncture the residual valve may damage components internal to the master cyl. It is highly recommended that you remove the residual valve instead of puncturing it!

[B] Second the brass tubing adapter at the rear of the master cylinder should have a minimum orifice diameter of .0625" or larger.

[C] reversing solenoid valve will normally be required.

[D] **WARNING: IF YOU MANUALLY LOCK OUT THE BRAKE COUPLER, AND FORGET TO REMOVE THE LOCK OUT MECHANISM, YOUR BRAKES WILL BE DISABLED DURING NORMAL FORWARD HIGHWAY TRAVEL !!**

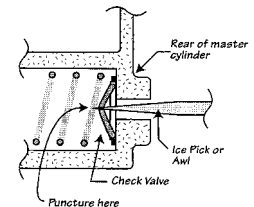

PART 6054
6000# RETRO-FIT
HYDRAULIC SURGE 10" DRUM BRAKE KIT

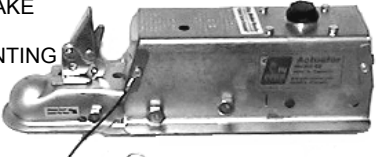

WITH GALV-X GALVANIZED FREE BACKING BRAKES AND STAINLESS STEEL BRAKELINE TUBING
NOTE: 6000# MAX CAPACITY IS ONLY AVAILABLE WHEN THE SYSTEM USES DUAL BRAKE AXLES. WHEN USED WITH A SINGLE BRAKE AXLE, THE CAPACITY IS 3500#, WHICH IS THE CAPACITY OF THE AXLE. FREE BACKING BRAKES AUTOMATICALLY DISENGAGE WHEN BACKING UP.

BRAKE KIT INCLUDES		TIEDOWN ENGINEERING® MODEL 66 6600# MAX CAPACITY SURGE BRAKE COUPLER WITH MOUNTING BOLTS
QTY	PART#	
1 EA	0142H	

1 PAIR	3121	GALV-X GALVANIZED FREE BACKING BRAKES	
--------	------	---------------------------------------	---

2 EA	0504	10" HYDRAULIC 5 ON 4 1/2" BRAKE HUB DRUMS, BEARINGS # 68149 INNER AND 44649 OUTER	
------	------	--	---

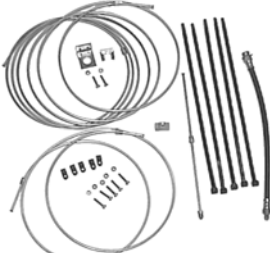
1 EA	3081	STAINLESS STEEL BRAKE LINE SINGLE AXLE TUBING KIT INCLUDES ALL COMPONENTS TO INSTALL TUBING FOR UP TO 20' BOAT	
------	------	---	---

IF AXLE IS REQUIRED WITH BRAKE KIT,
SELECT AXLE PART # FROM PAGE 3

BRAKE KIT WGT 95#	PART # 6054	KIT PRICE \$389.99
--------------------------	--------------------	---------------------------

PART # 6055
SECOND AXLE 10" DRUM BRAKE KIT
FOR USE WITH PART # 6054
SURGE BRAKE KIT WHEN ADDING BRAKES TO BOTH AXLES ON A TANDEM AXLE TRAILER

QTY	PART #	GALV-X GALVANIZED FREE BACKING BRAKES	
1 PAIR	3121		

2 EA	0504	10" HYDRAULIC 5 ON 4 1/2" BRAKE HUB DRUMS, BEARINGS # 68149 INNER AND 44649 OUTER	
------	------	--	---

1 KIT	3095	SECOND AXLE STAINLESS STEEL BRAKE LINE TUBING KIT	
-------	------	---	---

BRAKE KIT WGT 65#	PART # 6055	KIT PRICE \$249.95
--------------------------	--------------------	---------------------------

RETRO - FIT SURGE BRAKE INSTALLATION

THE RETRO-FIT INSTALLATION OF SURGE BRAKES REQUIRES CHANGING THE EXISTING IDLER COUPLER FOR THE SURGE BRAKE COUPLER AND THE REMOVAL OF THE IDLER HUBS AND INSTALLATION OF THE GALVANIZED BRAKES AND HUB DRUMS. IT IS ESSENTIAL THAT YOUR AXLE HAVE THE **4 HOLE BRAKE FLANGE PLATE**, AND USE BEARINGS # 68149 INNER AND 44649 OUTER. IF YOUR EXISTING AXLE HAS BRAKE FLANGES IN PLACE, THE RETRO-FIT INSTALLATION OF BRAKES IS RELATIVELY SIMPLE. YOUR GALVANIZED BRAKE CLUS BOLT DIRECTLY TO THE BRAKE FLANGES YOU REPLACE YOUR IDLER HUBS WITH THE NEW HUB DRUMS. AFTER REPLACING THE IDLER COUPLER WITH BRAKE COUPLER AND INSTALLING THE STAINLESS STEEL BRAKE LINE TUBING KIT, YOU MERELY BLEED AND ADJUST THE BRAKES AND YOU ARE READY TO GO.



PART # 0526 FRESH WATER WASH DOWN KIT

ADD TO BOAT TRAILER BRAKES TO WASH OUT SALT AND DIRT

KIT PRICE \$22.95

CONNECTS TO GARDEN HOSE AT HOME
1 KIT FOR ONE AXLE

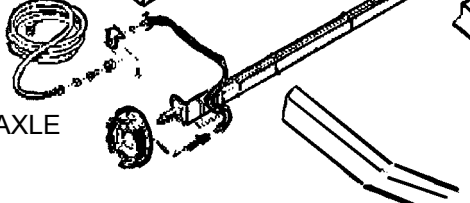

WGT 3#

NEW ALUMINUM REPLACEMENT WHEEL CYLINDER

10" OR 12" UNISERVO OR FREE-BACKING HYDRAULIC BRAKES
PART # 0537 (LEFT)
PART # 0538 (RIGHT)



PRICE EA SIDE \$23.95
 WT 2# EA
 NO PUSH ROD

REPLACEMENT CAST IRON WHEEL CYLINDER

10" OR 12" HYDRAULIC BRAKES
 UNISERVO OR FREE-BACKING

NO PUSH ROD

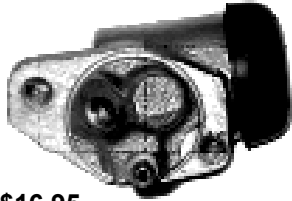

PART # 0534 (LEFT SIDE)
PART # 0535 (RIGHT SIDE)
 WT 2# EA

PRICE EACH SIDE \$16.95

HYDRAULIC BRAKE ADJUSTER SCREW KIT

PART #	SIZE	PRICE
0131	10" KIT	\$10.95
0132	12" KIT	\$12.95



WT .5#

STAINLESS STEEL BRAKE LINE TUBING

PART #	LENGTH	WT	PRICE
3082	12" - 1'	.3#	\$4.49
3083	18" - 1.5'	.4#	\$5.95
3084	24" - 2'	.5#	\$7.95
3085	36" - 3'	.6#	\$10.95
3086	48" - 4'	.7#	\$14.49
3087	60" - 5'	.8#	\$17.95
3088	72" - 6'	.9#	\$19.95
3096	78" - 6.5'	1#	\$21.95
3089	16' COIL	3#	\$48.95
5002	20' COIL	4.5#	\$59.50
4338	23' COIL	5#	\$68.50



PART# 4335X
 7" HYDRAULIC BRAKE CLUSTERS (1 PAIR) - UNISERVO I - LEFT & 1 - RIGHT PAINTED - **NOT GALVANIZED** **NOT FREE BACKING**
 WT PER PAIR 25#

PRICE PER PAIR
\$139.95



ATWOOD®

PART # 4336
FREE BACKING
 8 1/2" DUO-SERVO HYDRAULIC BRAKE CLUSTERS (1 PAIR) 1 - LEFT & 1 - RIGHT PAINTED - **NOT GALVANIZED**
 WT PER PAIR 20#

PRICE PER PAIR
\$189.95

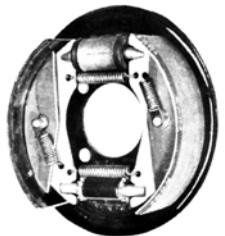

DICO®

FAX YOUR ORDER TO 1-800-359-8169
OR CALL 1-800-229-6690
www.championtrailers.com

GALV-X GALVANIZED FREE BACKING BRAKES

WITH NEW ALUMINUM WHEEL CYLINDER

CORROSION RESISTANT FREE BACKING BRAKES ALL SPRINGS ARE STAINLESS FREE BACKING BRAKES AUTOMATICALLY DISENGAGE WHEN BACKING UP!



COMES W/GALVANIZED MOUNTING BOLTS

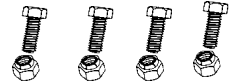

PART #	DESCRIPTION	WT	PRICE
3119	10" FREE BACKING (LEFT)	15#	\$68.95
3120	10" FREE BACKING (RIGHT)	15#	\$68.95
3121	10" FREE BACKING (PAIR)	27#	\$129.90
3122	12" FREE BACKING (LEFT)	20.5#	\$89.95
3123	12" FREE BACKING (RIGHT)	20.5#	\$89.95
3124	12" FREE BACKING (PAIR)	40.5#	\$174.95

STAINLESS STEEL SINGLE AXLE BRAKE TUBE KIT FOR DRUM BRAKES

PART # 3081	KIT WITH 16' MAINLINE	4#	\$89.95
PART # 4003	KIT WITH 20' MAINLINE	5#	\$99.95
PART # 4337	KIT WITH 23' MAINLINE	6#	\$107.95

QTY	PART #	DESCRIPTION
1		MAIN LINE TUBING
1	3088	6' COIL
1	3028	1' PIECE
1	0520	13" M/F HOSE
1	0516	BRASS TEE
5	4011	NYLON TUBE STRAP W/NUT AND BOLT
6	3091	14" NYLON TYWRAP

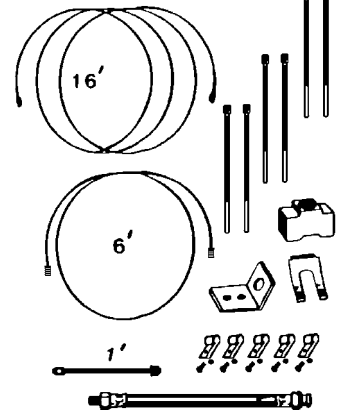

2ND AXLE STAINLESS STEEL BRAKE LINE TUBING KIT ADD TO KITS # 3081, 4033, OR 4337 FOR SECOND AXLE BRAKE INSTALLATION.

PART # 3095 \$48.50 WT 3#

QTY	PART #	DESCRIPTION
1	0521	18" M/M HOSE
2	4011	NYLON TUBE STRAP W/NUT AND BOLT
6	3091	14" NYLON TYWRAP
2	0513	BRASS TEE
1	3085	36" - 3' PIECE
1	3088	72" - 6' PIECE
1	3082	12" - 1' PIECE

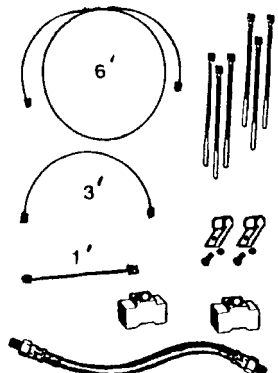

DICO MO 60 BRAKE COUPLER PARTS

PART #	ITEM	DESCRIPTION	WT	PRICE EA
23362	4	SHOCK DAMPER	.5#	\$28.95
43695	10	BREAKAWAY LEVER ASSY	.5#	\$9.95
40052	13	BREAKAWAY SPRING	.1#	\$1.85
23463	14	PUSHROD W/SPRING	.5#	\$16.95
23361	15	MASTER CYL W/RUBBER BOOT	2#	\$45.95
23414	16	MASTER CYLINDER GASKET	.2#	\$2.85
23566	22	MASTER CYLINDER COVER	.2#	\$3.95
23388	20,21	FILLER CAP AND GASKET	.2#	\$6.95
23389	21	GASKET ONLY	.1#	\$2.49
23383	27	MULTIFIT LATCH LOCK	.1#	\$2.95
40051	32	BREAKAWAY LEVER COVER	.1#	\$2.95
15026	37	MASTER CYL REPAIR KIT	.2#	\$15.95
12098	17	TUBING ADAPTOR	.1#	\$3.95

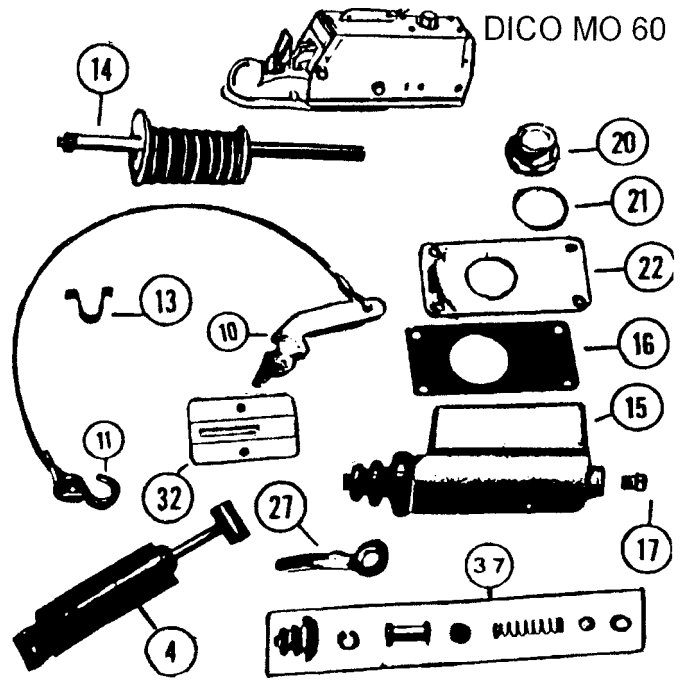
**DICO MO 10 BRAKE COUPLER PARTS**

PART #	ITEM	DESCRIPTION	WT	PRICE EA
10541	10	BREAKAWAY LEVER ASSY	3#	\$14.95
10552	11	RUBBER WEATHER SEAL	.1#	\$2.49
15070	16	PLASTIC CYLINDER COVER	.1#	\$2.95
23744	19,20,21	MASTER CYLINDER W/CAP AND PUSH ROD	7#	\$69.95
12503	21	FILLER CAP AND GASKET	.3#	\$13.95
3253		CAP GASKET ONLY	.1#	NA
10187	47	MASTER CYL REBUILD KIT <i>DOES NOT INCLUDE SPRING</i>	.2#	\$19.95
12099	22,23	TUBING ADAPTOR AND GASKET	.1#	\$4.95
83889	24	MASTER CYL CUSHION SPRING ASSY (LEFT AND RIGHT SIDE) SOLD PER PAIR	5#	\$39.95
12426	29	SHOCK DAMPERS (SOLD EA)	1#	\$28.95

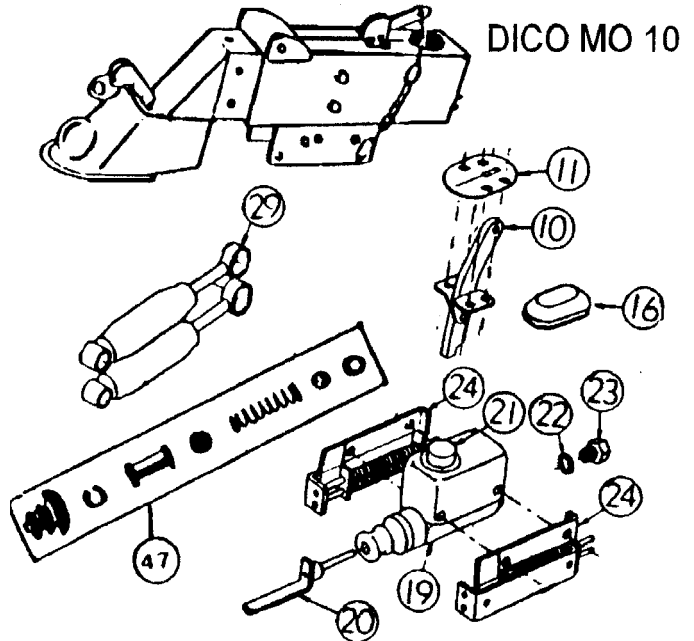
**ATWOOD 6000# BRAKE COUPLER PARTS**

PART #	ITEM	DESCRIPTION	WT	PRICE EA
85830	4	SHOCK ABSORBER REPLACEMENT KIT	1#	\$28.95
85870	7	MASTER CYLINDER FOR DISC BRAKES	2#	\$49.95
85908	15	FILLER CAP W/GASKET	.2#	\$6.95
85841	6	MASTER CYLINDER FOR DRUM BRAKES	2#	\$41.95
4341	8	RUBBER BOOT FOR MASTER CYLINDER (DOES NOT COME W/MASTER CYLINDER))	.2#	\$5.99

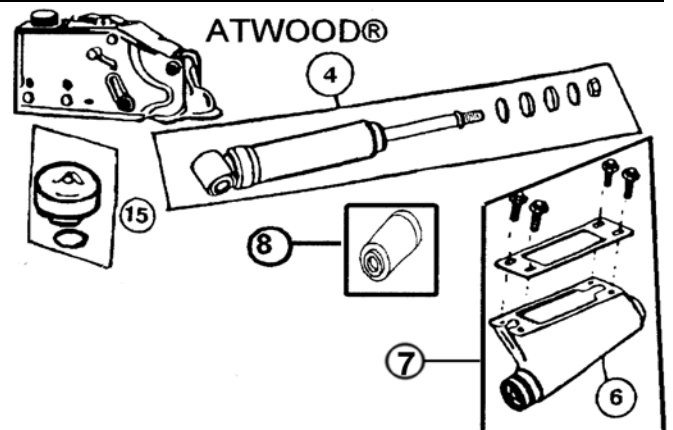

STAINLESS SPRING KIT FOR UNISERVO HYDRAULIC BRAKE CLUSTER

SPRINGS ARE **STAINLESS**
ALL OTHER PARTS ARE
TYPE 3 CADMIUM PLATED

(KIT FOR 1 BRAKE CLUSTER)

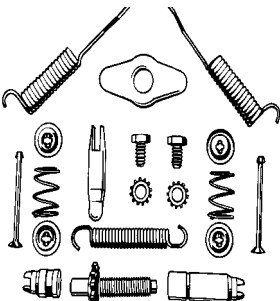

PART #	DESCRIPTION	WGT	PRICE/KIT
3135	KIT FOR 10" UNISERVO BRAKE	2.5#	\$24.95
3131	KIT FOR 12" UNISERVO BRAKE	2.5#	\$25.95



STAINLESS SPRING KIT FOR FREE BACKING HYDRAULIC BRAKE CLUSTER

SPRINGS ARE **STAINLESS**
ALL OTHER PARTS ARE
TYPE 3 CADMIUM PLATED

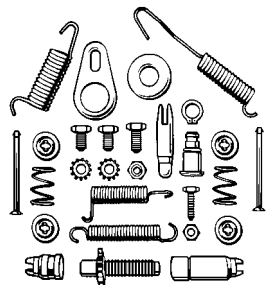
(KIT FOR 1 BRAKE CLUSTER)

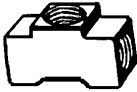

PART #	DESCRIPTION	WGT	PRICE/KIT
3136	KIT FOR 10" FREE BACKING BRAKE	2.5#	\$24.95
3137	KIT FOR 12" FREE BACKING BRAKE	2.5#	\$25.95

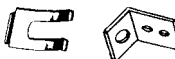
PART #	DESCRIPTION	WT	PRICE EA	
0516	BRASS 3/16" INVERTED FLARE BRAKE "TEE"	.2#	\$2.39	
0517	BRASS 3/16" FLARE COUPLER NUT	.2#	\$1.69	
3118	ZINC PLATED BRAKE HOSE MOUNTING BRKT W/SPRING CLIP	.2#	\$3.99	

TUBE ADAPTERS

1/8" MPT (MALE PIPE THREAD) WITH 3/16" INVERTED FLARE BRAKE TUBING FEMALE THREADS. MALE THREADS FIT MOST BRAKE COUPLER MASTER CYLINDERS

(EXCEPTION IS DICO MO 10 AND M0 20 BRAKE COUPLERS).

PART #	TUBE ADAPTORS	WT	PRICE
0518	SMALL ORIFICE FOR USE WITH DRUM BRAKES	.6#	\$2.95
0519	LARGE ORIFICE FOR USE WITH DISC BRAKES	.6#	\$2.95



**TO PLACE AN ORDER CALL 1-800-229-6690
OR FAX TO 1-800-359-8169**

FOR TECHNICAL ARTICLES VISIT OUR WEBSITE AT
www.championtrailers.com

HOT DIP GALV UNISERVO REPLACEMENT SHOE KIT

KIT = 1 PRIMARY &
1 SECONDARY SHOE
(DOES 1 SIDE OF 1 AXLE)
2 EA KITS ARE NEEDED
FOR BOTH BRAKES ON (1) AXLE

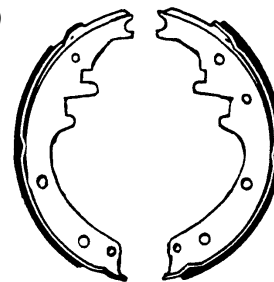

PART #	DESCRIPTION	WGT	PRICE/KIT
3132	SHOE KIT FOR 10" BRAKES	4#	\$29.95
3129	SHOE KIT FOR 12" BRAKES	4#	\$38.95

HOT DIP GALV FREE BACKING REPLACEMENT SHOE KIT

KIT = 1 PRIMARY & 1 SECONDARY SHOE
(DOES 1 SIDE ON 1 AXLE)
2 EA KITS ARE NEEDED
FOR BOTH BRAKES ON (1) AXLE

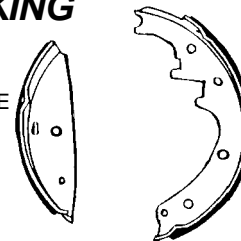

PART #	DESCRIPTION	WGT	PRICE/KIT
3133	FREE BACK SHOE KIT 10"	4#	\$29.95
3134	FREE BACK SHOE KIT 12"	6#	\$38.95



0520	13" MALE / FEMALE BRAKE HOSE	.5#	\$10.99
0521	18" MALE / MALE BRAKE HOSE	.6#	\$11.95
6108	18" MALE / FEMALE BRAKE HOSE	.6#	\$11.95

DICO® MO-10 AND MO-20 MASTER CYLINDER DISC BRAKE TUBE ADAPTER KIT

CONTAINS 1 - MO 10/20 TUBE ADAPTER W / BRONZE SEALING WASHER SPECIALLY MACHINED FOR LARGE ORFICE & 1/8" NPT THREADS THAT WILL ACCEPT THE MALE THREADS FROM BLOCKING SOLENOID PART# 1507

ALSO CONTAINS 1 - LARGE ORFICE (1/8" NPT X 3/16 IF) TUBING ADAPTOR FOR CONNECTION TO BACK OF REVERSING SOLENOID AND BRAKE TUBING OR FLEX HOSE

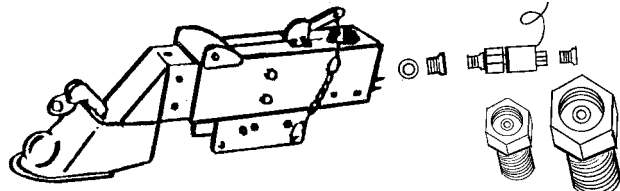

PART # 12099DB
WGT .2# **PRICE \$19.95**
DOES NOT INCLUDE REVERSING SOLENOID



ELECTRIC BRAKES

SOLD PER PAIR
1 - LEFT SIDE
1 - RIGHT SIDE

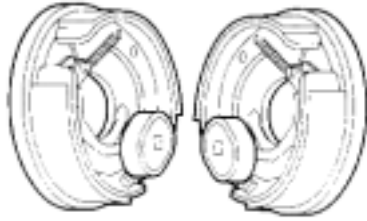

PART #	DESCRIPTION	WT PER PAIR	PRICE PER PAIR
4342	7" DEXTER® (PAIR)	20#	\$89.95
3125	10" AL-KO®(PAIR)	24#	\$76.95
3128	12" AL-KO®(PAIR)	33#	\$99.95

TRAILER WIRING PLUGS

HIGH IMPACT POLY CARBONATE TRAILER PLUGS AND RECEPTACLES WITH BRASS CONTACTS. USED ON MOST UTILITY AND RV TRAILERS

STANDARD 6 POLE ROUND PIN



RV STYLE 7 PIN (FLAT) MATCHES OTHER 7 PIN RV TYPE

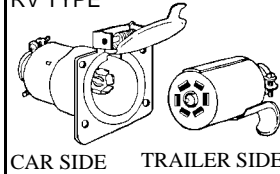

PART#	DESCRIPTION	WT	PRICE EA
4389	6 POLE TRLR PLUG	.2#	\$6.95
4390	6 POLE CAR RECEPTACLE	.2#	\$6.95
4391	7 PIN (RV) TRLR PLUG	.2#	\$6.95
4392	7 PIN (RV) CAR RECEPTACLE	.2#	\$6.95

PART # 4399
MOUNTING BRACKET FOR 6 POLE CAR SIDE RECEPTACLE



PART # 4400
MOUNTING BRACKET FOR 7 PIN RV STYLE CAR SIDE RECEPTACLE

WT .4#
PRICE EA \$1.99

PART # 4397
6 POLE ROUND TO 4 POLE FLAT RECEPTACLE CONVERTOR. CHANGES 6 POLE ROUND PIN TO ACCEPT FLAT 4 POLE PLUG



WT .2#
PRICE EA \$9.95

PART # 4398
7 FLAT PIN (RV) RECEPTACLE CONVERTS TO ACCEPT 4 POLE FLAT PLUG

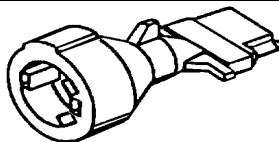

WT .2#
PRICE EA \$9.95

TRAILER WIRING CABLE
MAXIMUM LENGTH 500 FT
SOLD PER FOOT

PART#	SIZE	WT	PRICE/FT
3396	16/4 FLAT WIRE	1#	\$0.39
3397	16/6 ROUND CABLE	1.5#	\$0.69
3398	14/6 ROUND CABLE	2#	\$0.95
3399	7 CONDUCTOR - 3# 12 4# 14	2#	\$1.49



CUT ELECTRIC CABLE LENGTHS REQUIRE A 50% RESTOCKING CHARGE FOR RETURN (PLUS SHIPPING).

TAP USA® BRAKE MASTER ELECTRONIC BRAKE CONTROLLER FOR 2 TO 6 BRAKES

ADJUSTABLE OUTPUT POWER BAR
10 LED BAR GRAPH DISPLAY
INDICATES POWER OUTPUT LEVEL
GREEN LED LIGHT CONFIRMS CONNECTION TO TRAILER.
MANUAL OVER RIDE COMES COMPLETE WITH MOUNTING BRACKET AND INSTRUCTIONS.



PART # TAP945
WT 2#

PRICE EA \$57.95

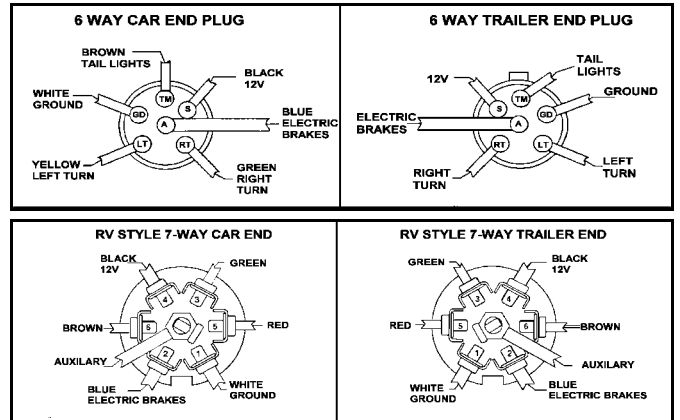

AUTO RESET CIRCUIT BREAKER

USED IN SUPPLY CIRCUIT FOR ELECTRIC BRAKE CONTROLLERS

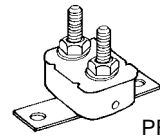

PART #	CAPACITY	WT	PRICE EA
4352	20 AMP AUTO RESET	.1#	\$4.99

12V EMERGENCY BREAKAWAY KIT AND COMPONENTS FOR ELECTRIC BRAKES

TAP USA® WITH LOCKABLE BATTERY BOX

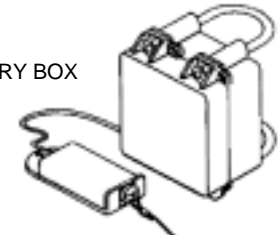
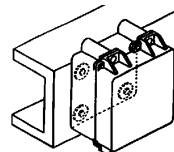

PART #	DESCRIPTION	WT	PRICE
TAP947	COMPLETE KIT W/LOCKABLE BOX CHARGER, BATTERY AND SWITCH	6#	\$56.95
TAP946	BREAKAWAY KIT ABOVE WITHOUT THE BATTERY CHARGER	6#	\$48.95
BRK948	BREAKAWAY SWITCH ONLY	.3#	\$ 9.95
BRK950	BATTERY TRICKLE CHARGER ONLY	.3#	\$19.95
BRK951	12VDC BATTERY ONLY	5#	\$23.95

PART # 4388
2 CONDUCTOR # 14 GA ELECTRIC BRAKE WIRE
WT PER FT .3#
PRICE PER FT \$0.39



PART # 4384
TRAILER WIRE FLEX-GUARD®
1/2" ID BLACK POLYETHYLENE TRAILER WIRING PROTECTOR FLEXIBLE TUBING HAS A SLIT DOWN IT'S CONTINUOUS LENGTH SO THAT IT EASILY SNAPS OVER EXISTING WIRING.



WT PER FT.2#

PRICE PER FT \$0.99



NEW **FROM FULTON® PERFORMANCE PRODUCTS**
 FUL-STOP TRAILER BRAKES
 FORMERLY AMRAD® BRAKES

NEW

HOT DIP GALVANIZED ELECTRIC BRAKES
 THE CONVENIENCE AND SAFETY
 OF ELECTRIC BRAKES WITH THE CORROSION
 RESISTANCE OF HOT DIP GALVANIZE COATING
 AND WITH STAINLESS STEEL SPRINGS



PART #	DESCRIPTION	WGT	PRICE PER
GEB10L	10" GALV ELECTRIC BRAKE- LEFT	15#	\$79.95 EA
GEB10R	10" GALV ELECTRIC BRAKE- RIGHT	15#	\$79.95 EA
GEB10P	10" GALV ELECTRIC BRAKE- PAIR	30#	\$158.50 PR
GEB12L	12" GALV ELECTRIC BRAKE- LEFT	19#	\$109.95 EA
GEB12R	12" GALV ELECTRIC BRAKE- RIGHT	19#	\$109.95 EA
GEB12P	12" GAVL ELECTRIC BRAKE- PAIR	39#	\$218.50 PR

PAINTED ELECTRIC BRAKE SHOES

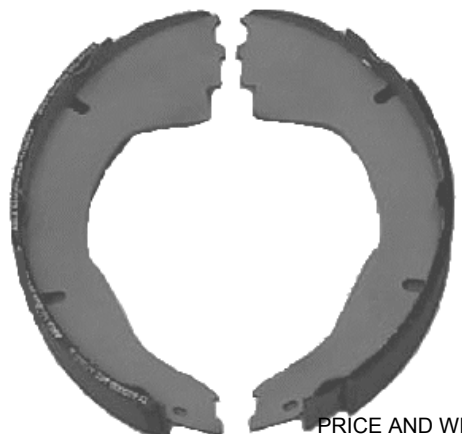

PRICE AND WEIGHT PER PAIR
 1 PAIR = 1 PRIMARY AND 1 SECONDARY SHOE

ELECTRIC BRAKE MAGNETS

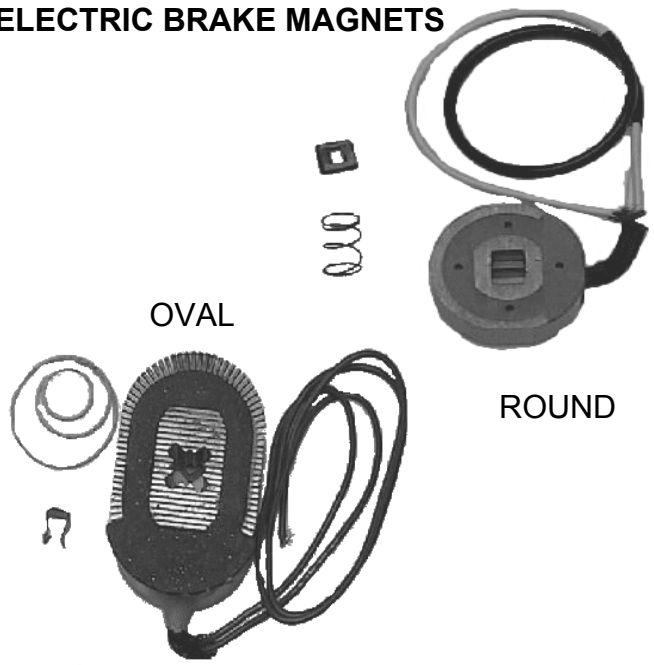

OVAL

ROUND

PART #	DESCRIPTION	WGT/PR	PRICE/PR	PART#	DESCRIPTION	WT	PRICE
4343	7" DEXTER®	8#	\$24.95	4348	7" ROUND KIT	.5	\$22.95
4344	10" ALKO®	9#	\$21.95	4349	10" OVAL	.5	\$21.95
0156D	10" DEXTER®	9#	\$21.95	4350	12" OVAL	.5	\$22.95
4345	12 ½" ALKO®	10#	\$24.95				
4346	12 ½" DEXTER®	10#	\$26.95				
4347	12" HAYES®	10#	\$27.95				

TIEDOWN ENGINEERING®

HYDRAULIC SURGE BRAKE COUPLERS

FEATURING: LARGER CAPACITY- ALL ALUMINUM MASTER CYLINDERS - WITH BUILT IN SHOCK DAMPER**
DOUBLE LOCKING COUPLER LATCH** RAISED FILL CAP DESIGN - KEEPS WATER OUT OF MASTER
CYLINDER** REVERSE LOCK OUT OPTION** EASY TO USE MECHANICAL - QUICK BLEED ACCESS**

MODEL 66 - 6600# MAX GVWR CAPACITY
FITS 2" COUPLER BALL

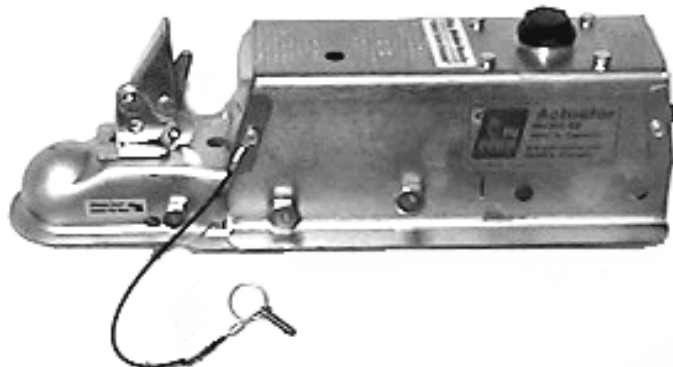

PART# 0142H -
FOR HUB DRUM INSTALLATION ONLY! WGT:
27# **PRICE EACH: \$109.99**

PART# 0143DB-
FOR DISC BRAKES ONLY!
WGT: 27# **PRICE EACH: \$119.99**

MODEL 80 - 8000# MAX GVWR CAPACITY
FITS 2" COUPLER BALL
*TIEDOWN MODEL 80
BRAKE COUPLERS
COMES WITH AN
8000# RATED
2" BALL*

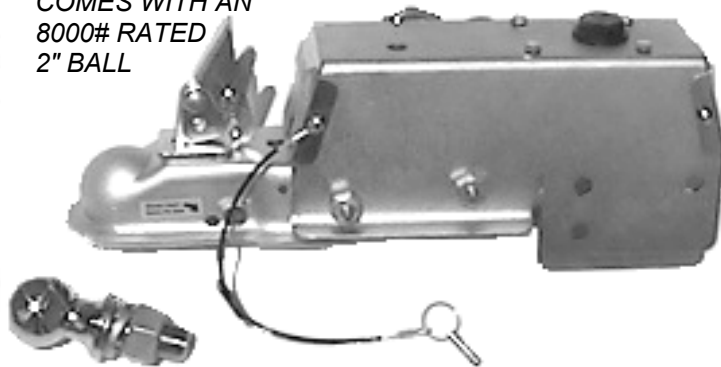

PART# 0153H - FOR HUB DRUM INSTALLATION ONLY!
WGT: 29# **PRICE EACH: \$169.95**

PART# 0154DB - FOR DISC BRAKES ONLY!
WGT: 29# **PRICE EACH: \$179.95**

DICO/TITAN® - MODEL 60 FASLOK

6000# MAX GVWR CAPACITY
FITS 2" COUPLER BALL

PART# MO60FL

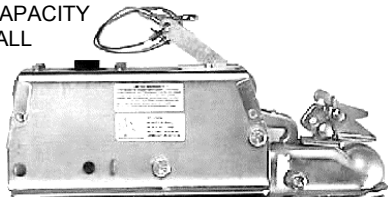

WGT: 26# **PRICE EACH: \$109.90**

DICO/TITAN® - MODEL 60 MULTI FIT

6000# MAX GVWR CAPACITY - FITS FROM 1 7/8" -
2" COUPLER BALL

PART# MO60MF

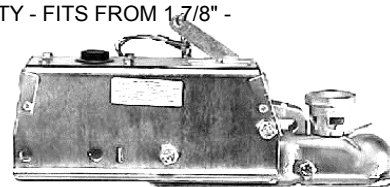

WGT: 26# **PRICE EACH: \$109.90**

DICO/TITAN® - MODEL 10

10,000# GVWR CAPACITY
FITS 2 5/16" COUPLER BALL

PART# 0502

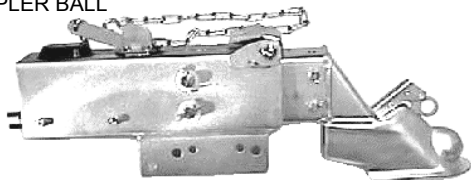

WGT: 60# **PRICE EACH: \$299.95**

DICO/TITAN® - MODEL 20

20,000# GVWR CAPACITY
FITS 2 5/16" COUPLER BALL

PART# 0503

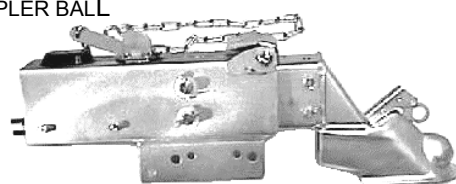

WGT: 73# **PRICE EACH: \$378.95**

DICO/TITAN® - MODEL 6

7500# GVWR CAPACITY
FITS 2 5/16" COUPLER BALL

PART# 3130

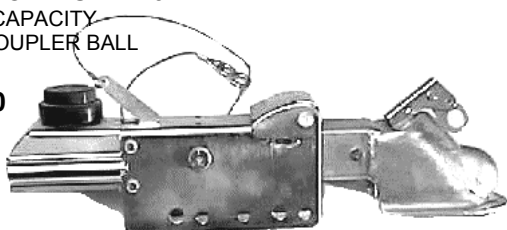

WGT: 54# **PRICE EACH: \$249.00**

DEMCO® 6000#GVWR DRUM BRAKE COUPLER

FITS 2" COUPLER BALL

PART# DA66



WGT: 27# **PRICE EACH: \$109.90**

****NEW** L.E.D. (LIGHT EMITTING DIODE) LITES**

SOLID STATE * ELECTRONIC * 12 VDC WATER PROOF LITES

OVAL LED LITE

REPLACES EXISTING OVAL TAIL LITES (COMES WITH GASKET) DOES NOT COME WITH PLUG. WIRES DIRECTLY TO EXISTING WIRE HARNESS



PART# 0157 WGT EA: .3#
PRICE EA: \$28.95

RETRO-FIT OVAL TAIL LITE KIT WITH HEAVY DUTY HOT DIP GALVANIZED MOUNTING BRACKET

(SOLD PER PAIR)
 1 LEFT / 1 RIGHT

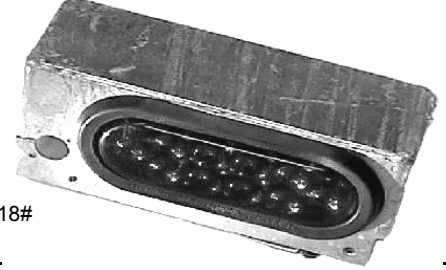

PART# 0165 WGT/PR: 18#
PRICE/PR: \$109.95

SURFACE MOUNT LED SIDE MARKER LITES

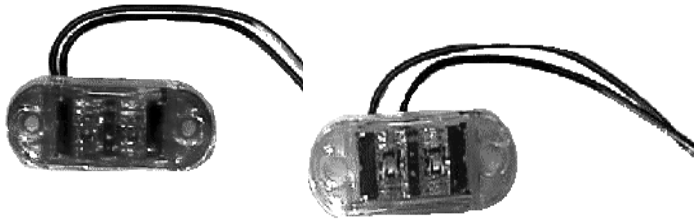

PART# 0158 AMBER
 PART# 0159 RED WGT EA: 1#
PRICE EA: \$7.95

HEAVY DUTY HOT DIP GALVANIZED OVAL TAIL LITE MOUNTING BRACKET

(SOLD PER PAIR)
 1 LEFT- 1 RIGHT

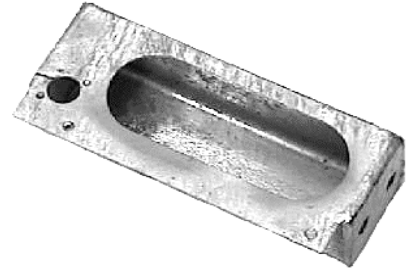

PART# 0166 WGT/PR: 17#
PRICE/PR: \$55.99

LED REPLACEMENT LITES FOR ROUND BASS BOAT STYLE SIDE MARKER LITES

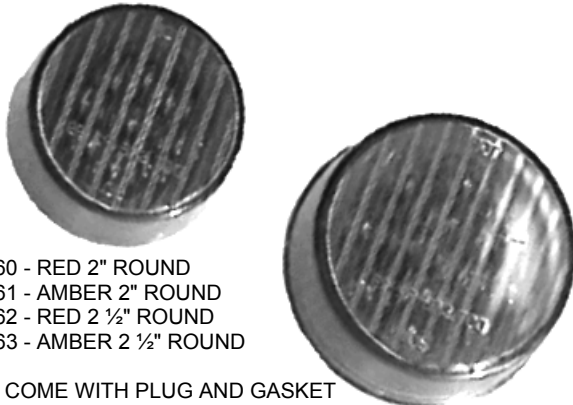

PART# 0160 - RED 2" ROUND
 PART# 0161 - AMBER 2" ROUND
 PART# 0162 - RED 2 1/2" ROUND
 PART# 0163 - AMBER 2 1/2" ROUND

ALL LITES COME WITH PLUG AND GASKET
 WGT EA: .2# **PRICE EA: \$12.95**

6 POLE ROUND AND 7 POLE RV FLAT STYLE FACTORY MOLDED PLUG WITH 8' FACTORY WHIP



PART# 0169 - 6 POLE ROUND WGT:5# **PRICE EA : \$15.95**
 PART# 0170 - 7POLE RV FLAT WGT: 6# **PRICE EA: \$18.95**

SURFACE MOUNT OVAL LED TAIL LITE

MOUNTS WITH 2 OR 4 SCREWS (SCREWS NOT PROVIDED) TO TRAILER FRAME. REQUIRES 1" HOLE THRU TRAILER FRAME IN REAR FOR WIRE OUTLET.

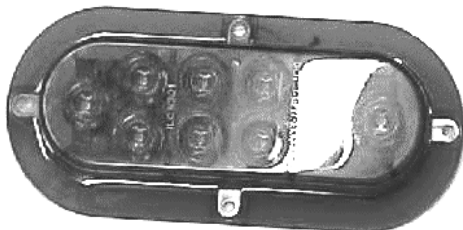

PART# 0164 WGT: .4#
PRICE EA: \$27.95

WESBAR* 5 POLE FLAT PLUG WIRE HARNESS.

HAS 1 EXTRA WIRE FOR REVERSING SOLONOID

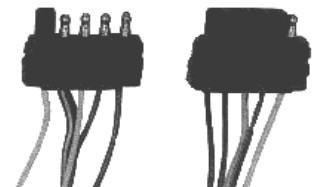

PART# 0167 - 5 POLE FLAT CAR SIDE (6') WGT: 1# **PRICE: \$6.95**

PART# 0168 - 5 POLE FLAT TRAILER SIDE (4') WGT: 1# **PRICE" \$6.95**

**TITELITE® OVAL
SUBMERSIBLE TAIL LIGHT**

HERMETICALLY SEALED FOR
100% WATER PROOF OPERATION.
COMES WITH MOUNTING GASKET
AND WIRING PLUG (BASS BOAT STYLE)

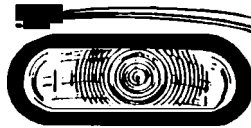

PART # 1101
WT 1#
PRICE EA \$9.95

**TITELITE® OVAL
REPLACEMENT TAIL
LIGHT ONLY**

(NO GASKET OR PLUG)
REPLACES OVAL TAIL LIGHT ON
BASS BOAT TRAILERS



PART # 4375
WT .7#
PRICE EA \$8.95

**WESBAR® SEAL BEAM
SUBMERSIBLE
TRIPLE LIGHT BAR**

WITH STAINLESS STEEL MOUNTING FRAME
REQUIRED ON ALL TRAILERS OVER 80" WIDE



PART # 3160
WT 1.5#
PRICE EA. \$13.95

**TITELITE®
SUBMERSIBLE
LICENSE PLATE LIGHT**

WITH WIRING PLUG
REQUIRES A 3/4" DIA HOLE



PART # 1105
WT .2#
PRICE EA \$3.95

**TRAILER WIRING
HARNESS**

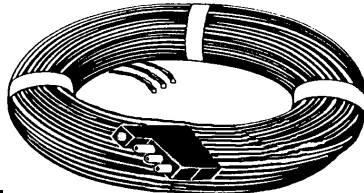

4 POLE FLAT PLUG

PART #	DESCRIPTION	A/B	WT	PRICE
4376	25' TRAILER WIRING HARNESS	A	2#	\$9.95
4377	30' TRAILER WIRING HARNESS	A	2.5#	\$12.95
4378	4' CAR SIDE TRUNK CONNECTOR 4 POLE FLAT PLUG	B	1#	\$2.95

**SUPER REFLECTIVE
RED/WHITE SAFETY TAPE**

(2" WIDE) MICRO PRISM
TECHNOLOGY MAKES
THIS REFLECTIVE,
SELF-ADHESIVE TAPE
VISIBLE FROM LONG DISTANCES.
PROTECT YOUR OUR BOARD FROM REAR END
COLLISION. THIS IS THE SAME TAPE YOU SEE ON 18 WHEELERS
NATION WIDE. PEEL & STICK ADHERES TO ALMOST ANY
SURFACE INCLUDING METAL AND GLASS.

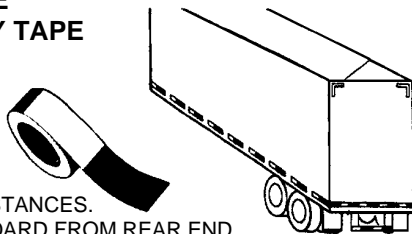

PART # 4385
WT PER FT .1#
PRICE PER FT \$2.89

**PLASTIC LICENSE
PLATE MOUNTING
BRACKET**

UNIVERSAL 2 HOLE MOUNT

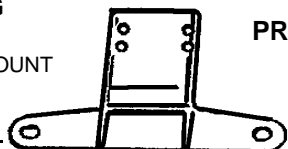

PART # 1008
WT .1#
PRICE EA \$1.95

**DRYLAUNCH®
SUBMERSIBLE "BELL
JAR" RECTANGULAR
7 FUNCTION TAIL LIGHT**

MOUNTS ON LEFT OR RIGHT SIDE
COMES WITH MOUNTING BOLTS
AND SIDE REFLECTORS

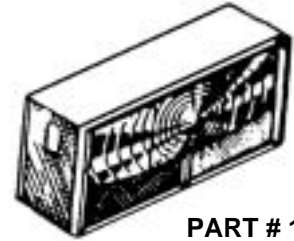

PART # 1004
WT 1.5#
PRICE EA \$9.99

**DRYLAUNCH® ROUND
SUBMERSIBLE
7 FUNCTION "BELL JAR"
TAIL LIGHT**

WITH SIDE REFLECTOR AND
MOUNTING BOLTS
AIR TRAP DESIGN KEEPS
WATER AWAY FROM BULB

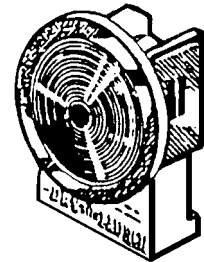

PART # 3158 - LEFT
PART # 3159 - RIGHT
WT 1.5#
PRICE EA \$9.99

**DRYLAUNCH®
SUBMERSIBLE
TRIPLE LIGHT BAR**

FLEXIBLE CROSS BAR ALLOWS FOR MOUNTING ON STRAIGHT
OR "V" CROSS MEMBERS

THIS LIGHT IS REQUIRED ON ALL TRAILERS OVER 80" WIDE



PART # 1009
WT .5#
PRICE EA. \$11.95

**ZINC PLATED WIRE
MOUNTING SPRING
CLIPS**

(10 PER PACK)



PART # 1012
WT .1#
PRICE /PACK \$2.80

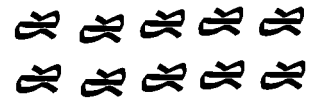

**PINCH TYPE SPLIT WIRE
CONNECTOR**

ALLOWS CONNECTION TO MAIN LINE
WITHOUT
CUTTING WIRE.

(5 PER PACK)

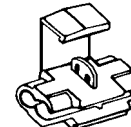

PART # 1011
WT .1#
PRICE/PACK \$1.60

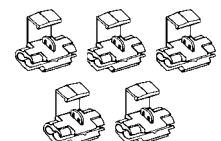

**HOT DIP GALV
LIGHT
MOUNTING
ANGLE BRACKETS**

W/ " MOUNTING BOLTS



PART # 3167
WT 1#
PRICE PER PAIR \$6.95

VISIT OUR WEB SITE FOR TECHNICAL INFORMATION ARTICLES
www.championtrailers.com

WESBAR® WATER PROOF TAIL LIGHT

TOTALLY SEALED
SUBMERSIBLE
LIGHT BULB
CAPSULE
ASSURES THAT
NO WATER GETS
TO BULBS OR
BULB CONTACTS.



SEALED CAPSULE CAN BE REPLACED IN THE EVENT OF BULB FAILURE WITH OUT REPLACING OUTER HOUSING. LOW PROFILE MEASURES 8" L X 2 7/8 X 2 3.4" D STANDARD TAIL LIGHT 2 BOLT MOUNTING

PART # 4382 - RIGHT LIGHT WT 2#
PART # 4380 - LEFT LIGHT PRICE EA. \$10.99

WESBAR® TOTALLY SEALED SUBMERSIBLE REPLACEMENT LIGHTCAPSULE

FITS WESBAR®
LOW PROFILE
TAIL # 4382 AND
4380 ABOVE



PART #4381 WT 1# PRICE EA \$7.99

SUBMERSIBLE SIDE MARKER LIGHTS

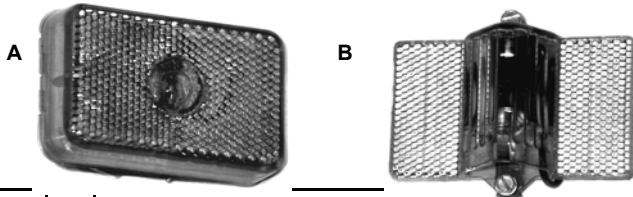

PART #	A/B	DESCRIPTION	WT	PRICE EA.
3161	A	WESBAR SEALED AMBER SIDELIGHT WITH 3/8" PLASTIC NIPPLE	.2#	\$3.99
3162	A	WESBAR SEALED RED SIDELIGHT WITH 3/8" PLASTIC NIPPLE	.2#	\$3.99
1006	B	DRYLAUNCH BELLJAR AMBER SIDELIGHT	.2#	\$3.99
1007	B	DRYLAUNCH BELLJAR RED SIDELIGHT	.2#	\$3.99

WESBAR® BEST WATERPROOF SIDE MARKER LIGHT AVAILABLE

(NO REFLECTOR)

TOTALLY SEALED WITH STAINLESS BASE AND 1/4" STUD MOUNT



6115	AMBER WATERPROOF SIDE LIGHT	.2#	\$4.79
6116	RED WATERPROOF SIDE LIGHT	.2#	\$4.79

PEEL & STICK REFLECTORS

1 1/2" H x 3" W

PART # 6101 RED REFLECTOR
PART # 6102 AMBER REFLECTOR
WT .1#

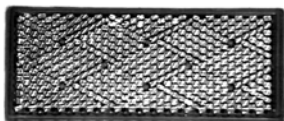

PRICE EA. \$.99

UTILITY TRAILER LIGHT WIRING KIT (NOT SUBMERSIBLE)

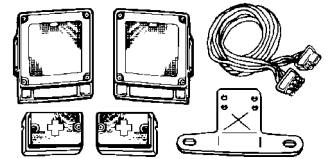

INCLUDES:
2 - TAIL LIGHTS
2 - SIDE MARKER LIGHTS
1 - LICENSE PLATE BRACKET
1 - 25' WIRING HARNESS
WIRING CONNECTORS AND
WIRE MOUNT CLIPS

PART # 4386
WT 3#

PRICE EA. \$24.95

WESBAR® WATERPROOF LOW PROFILE TAIL LIGHT KIT



PART # 4394
WGT 4#

PRICE PER KIT \$32.95

DRYLAUNCH® SUBMERSIBLE AIR TRAPPING DESIGN TAIL LIGHT KIT

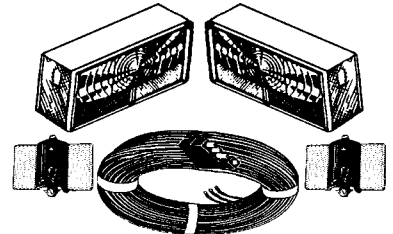

PART # 1010
WGT 4#

PRICE PER KIT \$28.95

FLAT 4 POLE MALE/FEMALE PLUG EXTENSION



PART #	DESCRIPTION	WGT	PRICE
1520	12" 4 POLE EXTENSION PLUG	.2#	\$3.95
1113	48" 4 POLE EXTENSION PLUG	.3#	\$5.95

GALVANIZED LIGHT MOUNTING BRACKETS TO MOUNT LIGHTS ON PVC GUIDE POSTS MOUNTING BOLTS NOT INCLUDED

PART # 4401
WT 2#



KIT PRICE \$8.95

ZINC PLATED LIGHT BRACKETS

& U-BOLTS TO FIT
1 1/2" BOX TUBE GUIDE KITS

PART # 4402
WT 3#

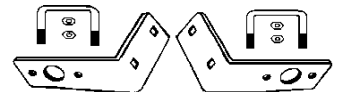

KIT PRICE \$9.95

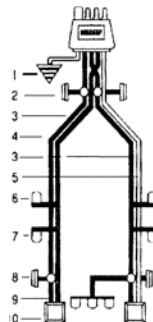

1. White Wire — ground to trailer frame
2. Side Marker Lights - Amber
3. Brown Wire
4. Yellow Wire
5. Green Wire
6. Clearance Lamps - Amber
7. Clearance Lamps - Red
8. Side Marker Lights - Red
9. I.D. Light Bar - Red
10. Tail, Stop and Turn Lights

Color coded for conformity to SAE, NMMA and TMA standards. WESBAR wire is a snap to install. Color coding is:

WHITE - ground	YELLOW - left turn and stop lights
BROWN - tail lights	GREEN - right turn and stop lights
side marker lights	
clearance lights	

**ATWOOD®
DELUXE
POWER JACK**

POWERFUL
12 VOLT MOTOR
LIFTS UP TO 2500#
HAS BUILT IN LIGHT
(INCLUDES MANUAL
HANDLE)

**PART # 80515
DELUXE 2500# JACK
WGT 30#**

PRICE EA \$229.90

**PART # 87891
REPLACEMENT
MANUAL DRIVE
HANDLE
WGT 5#**

PRICE EA \$ 19.95



**FULTON®
2000#
ZINC PLATED
DROP LEG JACK**

WITH MOUNTING
HARDWARE

PROVIDES UP TO
32" OF TONGUE HEIGHT
51" LOA - FULLY EXTENDED
25" LOA - FULLY RETRACTED

FITS UP TO
3" X 5" TONGUE

**PART #3436
WGT 25#**

PRICE \$59.95

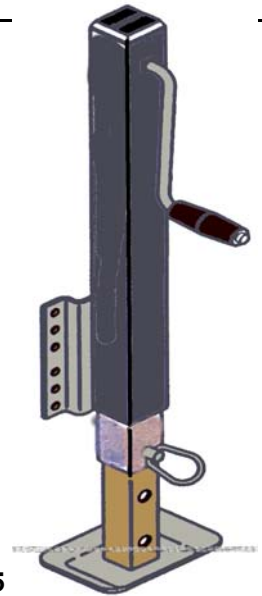

**BASS BOAT SIDE MARKER LIGHTS BY WESBAR®
ALL LIGHTS ARE WATER PROOF**

**RECTANGULAR
SNAP IN STYLE**

EACH KIT COMES WITH
LIGHT - BASE - AND PLUG

**PART # 1114 AMBER
PART # 1115 RED
WGT .3#**

PRICE EACH KIT \$6.95

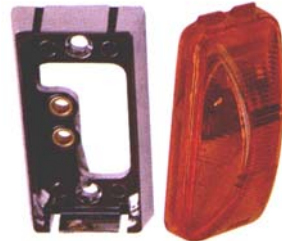

**ROUND TYPE
2" LIGHT BASE
DIAMETER**

W/RUBBER GROMMET
AND PLUG

**PART # 1116 AMBER
PART # 1117 RED
WGT .5#**

PRICE EACH KIT \$7.90



**ROUND TYPE
2 1/2" LIGHT BASE DIAMETER**

W/RUBBER GROMMET
AND PLUG

**PART # 1118
PART # 1119
WGT .6#**

PRICE EACH KIT \$7.99



**WEDGE TYPE
SIDE MARKER/CLEARANCE
LIGHT W/PIGTAIL**

**PART # 1020
WGT .3#**

PRICE EA \$4.99



**PART # 19051
7000# FULTON®
DROPLEG
SIDE WIND JACK**

2 1/2" SQ OUTER TUBING
(WELD ON INSTALLATION)

DROP LEG PROVIDES 13 1/2" OF
ADDITIONAL ADJUSTMENT

15" OF TRAVEL
22.95" FULL RETRACTED
51 45" FULLY EXTENDED
LARGE 6" X 8" FOOT ATTACHED
TO DROP LEG.
WT 28#

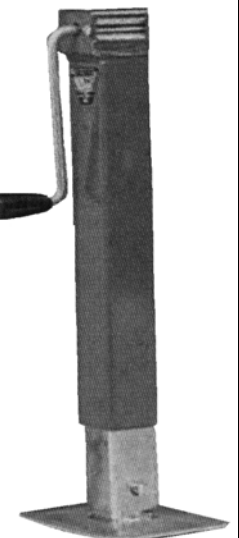

PRICE EA \$69.95

**BULLDOG® 10,000# LIFT
12,000# STATIC
LOAD CAPACITY**

JACK WITH HANDLE

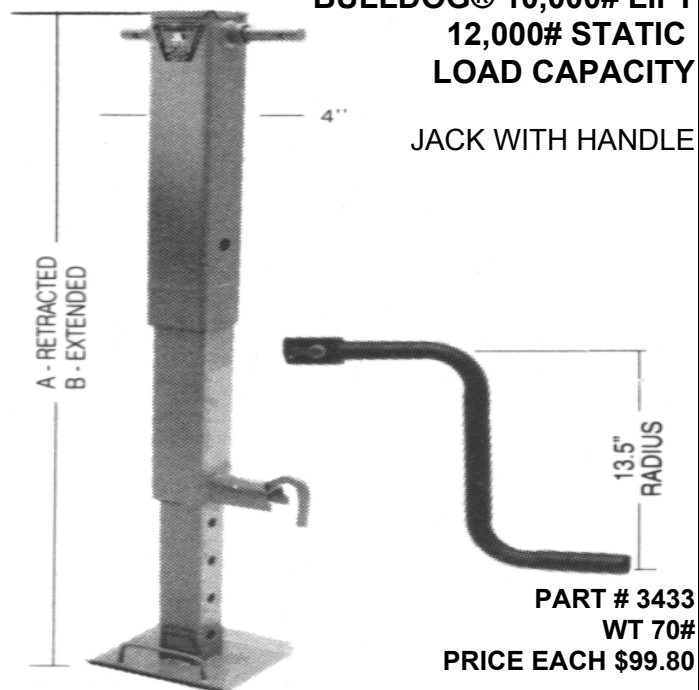

**PART # 3433
WT 70#**

PRICE EACH \$99.80

PART # 6034

**FULTON®
5000# TOP WIND
TILT PIN JACK**

4 X 7" FOOT

COMES WITH X-HVY 2"
MOUNTING NIPPLE BRACKET
HEIGHT TO GROUND
•15" RETRACTED
•30" EXTENDED

**WT 29#
PRICE EA. \$39.95**



**FULTON®
SWING-AWAY
JACKS**

FITS UP TO
3X5 TONGUE

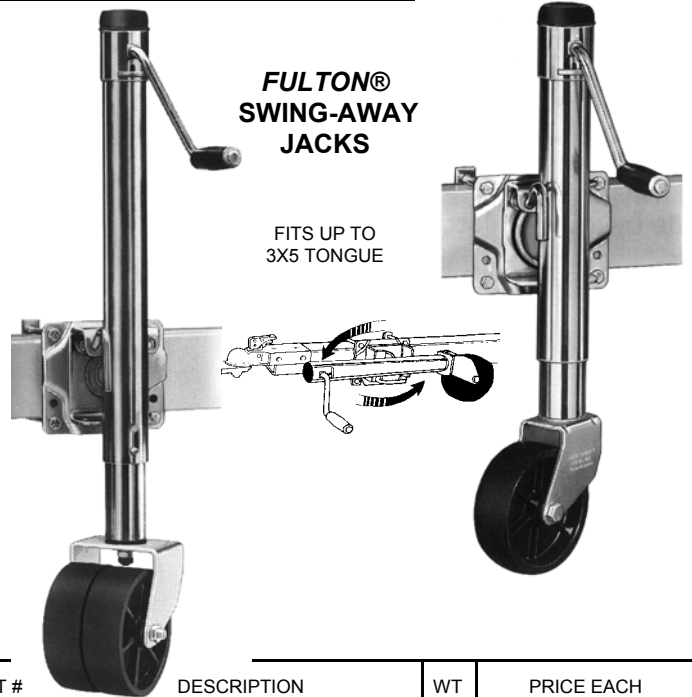

A-FRAME DROP-THRU JACKS

FIT A-FRAME COUPLERS
TOP WIND

ORDER FOOT OR CASTER SEPARATELY

FOOT

CASTER



PART #	DESCRIPTION	WT	PRICE EA
JA214	2000# A-FRAME JACK ONLY	14#	\$24.95
JA514	5000# A-FRAME JACK ONLY	15#	\$32.95
CE555	CASTER FOR FULTON A-FRAME JACK 2 1/16" ID	6#	\$14.95
F200	FOOT FOR FULTON A-FRAME JACK 2 1/16" ID	5#	\$9.95

**ATWOOD®
2000# SIDE WIND
A-FRAME JACK**

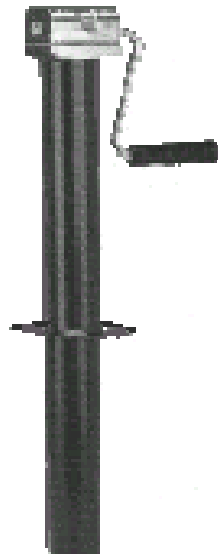

**PART # 3435
WGT 20#
PRICE \$39.95**

PART #	DESCRIPTION	WT	PRICE EACH
TJ503	800# SINGLE CASTER SWING AWAY JACK - UP TO 25" OF TONGUE LIFT	22#	\$34.95
TJD125	1200# DUAL WHEEL SWING AWAY JACK - UP TO 27" OF TONGUED LIFT	27#	\$49.99

FULTON JACK PARTS



PART #	DESCRIPTION	WT	PRICE
917507	2" CAP FOR TJ503	.1#	\$1.98
917503	2 1/4" CAP FOR TJD125	.2#	\$2.49
933301	HANDLE KIT TJ503 - 95 OR LATER	2#	\$9.95
933305	HANDLE KIT FOR TJD125 - 95 OR LATER	2#	\$9.95
933325	HANDLE KIT FOR TOPWIND AFRAME 97 OR LATER	2#	\$9.95
933302	BEVEL GEAR KIT FOR TJ503 - 95 OR LATER	2#	\$9.95
933306	BEVEL GEAR KIT FOR TJD125 - 95 OR LATER	2#	\$9.95
P9086	SNAP RING FOR SWING JACKS	.1#	\$2.95
6811	REPLACEMENT PHENOLIC WHEEL	1#	\$8.85

**FULTON®
1000# TRAILER
STABILIZER JACK**

HOLDS TRAILER LEVEL
KEEPS IT FROM ROCKING
14" LIFT

**PART # 6038
WGT 14#
PRICE PER PAIR \$31.95**



CORROSION RESISTANT METALS

- ▶ MAXIMUM LENGTH 7' FOR UPS SHIPMENT
- ▶ \$2.00 CUTTING CHARGE FOR EACH PIECE CUT
- ▶ ALL CUT METALS ARE NON RETURNABLE
- ▶ NO HOLES WILL BE DRILLED OR PUNCHED INTO METAL STOCK BY CHAMPION TRAILERS
- ▶ NO METAL STOCK WILL BE BENT BY CHAMPION TRAILERS

DUE TO THE FLUCTUATION IN STAINLESS AND ALUMINUM PRICES, CHAMPION TRAILERS RESERVES THE RIGHT TO CHANGE PRICES WITHOUT NOTICE.

GALVANIZED AND ALUMINUM BOX TUBE

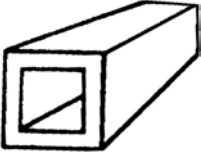

HOT DIP GALVANIZED BOX TUBE

PART #	DESCRIPTION	WGT PER FOOT	PRICE PER FT
7020	1/8 X 1 1/2 X 1 1/2"	2#	\$2.95
7021	3/16 X 2 X 2"	5#	\$5.50
0345	1/4 X 2 X 2"	6.5#	\$5.95
0346	3/16 X 2 X 3"	6.5#	\$5.95
1501	1/4 X 2 X 3"	8.8#	\$6.95
4177	1/8 X 3 X 3"	5.8#	\$6.70
7022	3/16 X 3 X 3"	7.5#	\$7.90
7023	3/16 X 3 X 4"	9.7#	\$9.20
7024	3/16 X 3 X 5"	11.3#	\$10.95

6061 ALUMINUM BOX TUBE

PART #	DESCRIPTION	WGT PER FOOT	PRICE PER FT
7025	3/16 X 3 X 3"	3#	\$8.45
7026	1/4 X 3 X 3"	4#	\$10.65

STAINLESS STEEL GALVANIZED AND ALUMINUM ANGLE



304 STAINLESS STEEL ANGLE

PART #	DESCRIPTION	WGT PER FOOT	PRICE PER FT
7044	1/8 X 2 X 2"	2.5#	\$5.65
7045	3/16 X 2 X 2"	3.5#	\$8.85
7046	1/4 X 2 X 2"	4.5#	\$11.95

HOT DIP GALVANIZED ANGLE IRON

PART #	DESCRIPTION	WGT PER FOOT	PRICE PER FT
7048	3/16 X 2 X 3"	4#	\$3.69

6061 ALUMINUM ANGLE

PART #	DESCRIPTION	WGT PER FOOT	PRICE PER FT
7049	3/16 X 2 X 2"	1#	\$4.65
7050	1/4 X 2 X 2"	1.5#	\$5.90
7051	3/8 X 2 X 2"	2#	\$8.45
0144	3/8 X3X3	3 1/2#	\$9.95

**TO PLACE AN ORDER CALL 800-229-6690
OR FAX YOUR ORDER TO 800-359-8169**

STAINLESS STEEL GALVANIZED AND ALUMINUM FLAT BAR



304 STAINLESS STEEL

PART #	DESCRIPTION	WGT PER FOOT	PRICE PER FOOT
7027	3/16 X 1 1/2"	1.8#	\$4.25
7028	3/16 X 2"	2#	\$5.85
7029	1/4 X 2"	2.5#	\$6.95

HOT DIP GALVANIZED FLAT BAR

PART #	DESCRIPTION	WGT PER FOOT	PRICE PER FOOT
7030	1/4 X 2	2#	\$1.95
7031	1/4 X 3	3#	\$2.95

6061 ALUMINUM FLAT BAR

PART #	DESCRIPTION	WGT PER FOOT	PRICE PER FOOT
7032	3/16 X 1 1/2"	.6#	\$1.79
7033	1/4 X 2"	.8#	\$2.98
7034	1/4 X 3"	1#	\$4.85
7035	3/8 X 2"	1#	\$4.85
7036	3/8 X 3"	1.5#	\$7.45

GALVANIZED MILL CHANNEL



PART #	DESCRIPTION	WGT PER FOOT	PRICE PER FOOT
7037	3" CHANNEL	4.5#	\$4.95
7038	4" CHANNEL	6#	\$5.95
7039	5" CHANNEL	7	\$6.95

95% ZINC RICH COLD GALV SPRAY PRIMER

PART # 3032 ★NOTE★ CANNOT SHIP VIA AIR
WT 2# UPS GROUND ONLY
PRICE \$6.95

USE AS TOUCH UP FOR GALVANIZED BOAT TRAILERS.

SUPERIOR ADHESION AND CORROSION RESISTANCE.

UNIQUE ELECTRO-GALVANIC "SELF-HEALING" PROCESS.

PRE-HEAT AREA TO BE SPRAYED FOR BEST RESULTS.



SINGLE TO TANDEM AXLE CONVERSION KIT

CONVERT YOUR SINGLE AXLE TRAILER TO A TANDEM TRAILER WITH THIS KIT.

KIT WILL ACCEPT 13" OR 14" TIRES

WHEN ORDERING, YOU MUST IDENTIFY YOUR CHANNEL OR BOX TUBE FRAME SIZE

KIT PART # 3257

THE KIT INCLUDES THE FOLLOWING:

PART #	QTY	DESCRIPTION	PRICE	WGT.
0605	1 PR.	HDG TANDEM AXLE UNDERCARRIAGE BRACKETS W/FENDER MOUNTING BRACKETS	\$119.95	70#
0611	1 PR.	64" HDG TANDEM FENDERS	\$89.90	46#
0401	2 PR.	1750# DOUBLE EYE SPRINGS	\$67.96	56#
0421	1 PR.	EQUALIZER	\$23.90	10#
0411	14 EA.	2½" SHACKLE LINKS	\$22.26	4.5#
4305	6 EA.	2 X 5" HDG SQUARE U-BOLTS	\$15.54	4#
0439	14 EA.	9/16 X 3 ½" GR. 5 SPRING BOLT AND NUT	\$22.26	6#
3201	8 EA.	¾" X 1¼ HDG BOLT AND NUT	\$3.92	1#
ATSF35 OR ABSF35	1 EA.	3500# AXLE W/BRAKE FLANGES	\$117.95	53#
0415	1 KIT	2" SQUARE U-BOLT TIE PLATE KIT	\$14.95	6#
0204	1 PR.	545 IDLER HUBS COMPLETE W/BEARINGS AND SEALS	\$47.90	24#
TOTAL PARTS PRICE			\$546.49	
TOTAL KIT PRICE			\$525.50	280#
SAVINGS			<\$20.99>	
<p>WHEN ORDERING YOU MUST IDENTIFY YOUR CHANNEL OR BOX TUBE FRAME SIZE TO PLACE AN ORDER CALL 800-229-6690</p>				

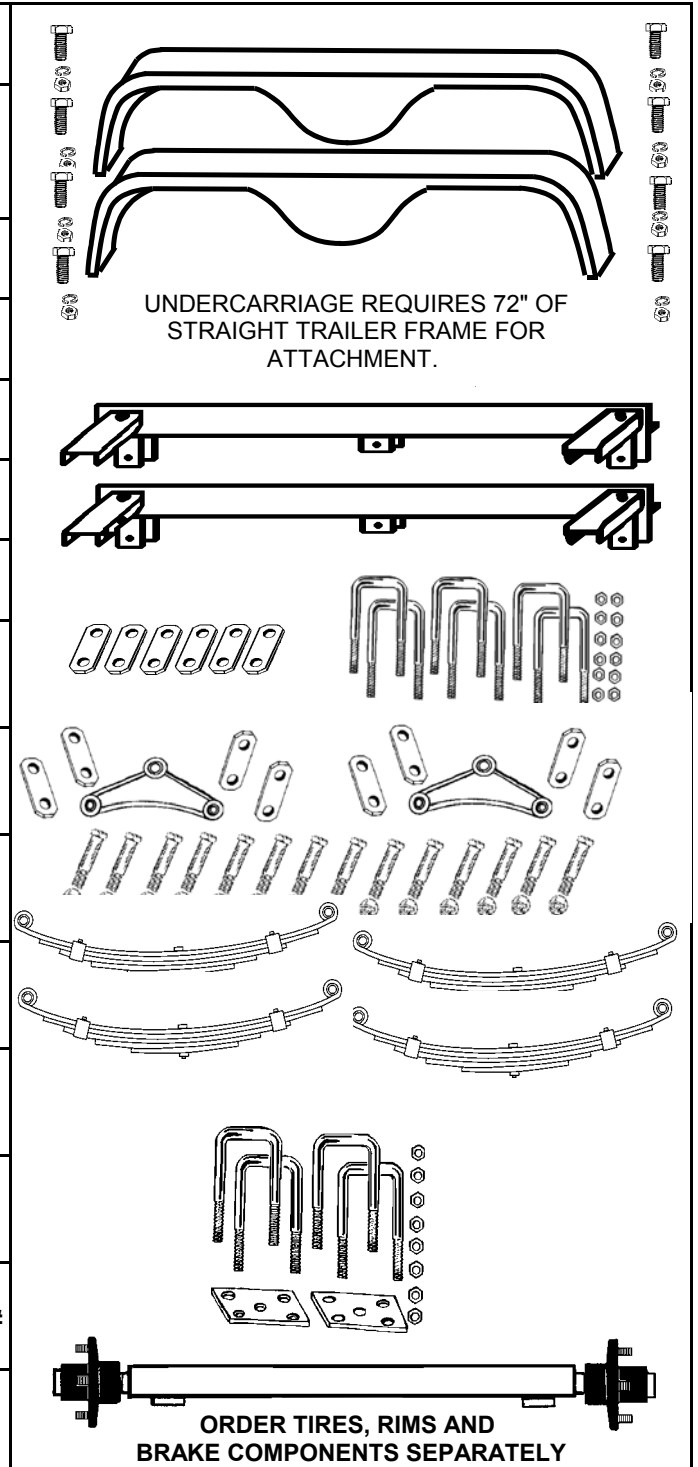

BUILD YOUR OWN TRAILER WITH OUR PARTS KIT (NO FRAME, YOU SUPPLY FRAME STEEL)

3500# SINGLE AXLE TRAILER PARTS KIT (NO FRAME)

KIT INCLUDES:
 1 - 3500# PAINTED IDLER AXLE 2 - D/E SPRINGS
 1 - A-FRAME COUPLER 1 - SPRING HANGER KIT
 2 - UNPAINTED 15" FENDERS 1 - 2000# JACK (NO FOOT)

PART #	TRACK	HUB BOLT PATTERN	KIT PRICE
4068	73"	5 ON 4.5 - FORD	\$208.85
4367	73"	5 ON 5 - CHEVY	\$208.85
4069	89"	5 ON 4.5 - FORD	\$209.95
4368	89"	5 ON 5 - CHEVY	\$209.95

DESIGN AND MATERIAL LIST FOR 5' X 8' - 3500# SINGLE AXLE TRAILER USING A 73" TRACK AXLE

# OF PIECES	ITEM	SIZE	LGTH	LOCATION
2	A	2 X 3" ANGLE	60"	FRAME AND REAR BOTTOM ANGLES
2	B	2 X 3" ANGLE	72"	TONGUE
2	C	2 X 3" ANGLE	77"	FENDER SUPPORT CROSS MEMBERS
4	D	2 X 3" ANGLE	96"	TOP AND BOTTOM MAIN FRAMES
1	E	2 X 3" ANGLE	64"	TOP FRONT RAIL
2	F	2 X 3" ANGLE	14"	FRONT VERTICAL SUPPORTS
6	G	2 X 3" ANGLE	17"	SIDE AND REAR VERTICAL SUPPORTS

USE WITH TRAILER PARTS KIT # 4068
FOR 545 HUB BOLT PATTERN OR
TRAILER PARTS KIT # 4367
FOR 550 CHEVY (5 ON 5") BOLT PATTERN

KIT WGT 154#

DESIGN INFORMATION CONTAINED IN THIS CATALOG IS NOT INTENDED TO PROVIDE TRAILER CAPACITY RECOMMENDATIONS. TYPE AND SIZE OF STRUCTURAL STEEL USED TO PRODUCE THE TRAILER FRAME MUST BE DETERMINED BY THE CUSTOMER TO FIT THE STRUCTURAL REQUIREMENTS OF HIS APPLIED LOAD.

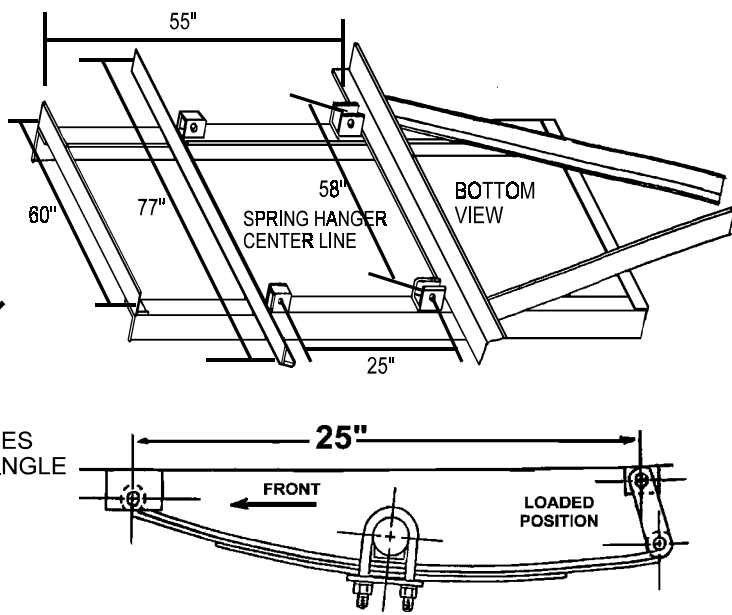
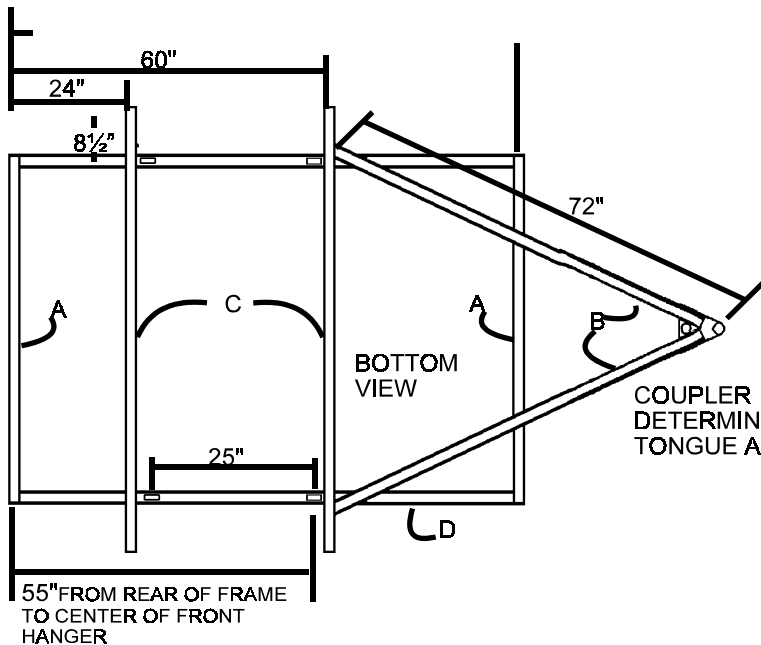
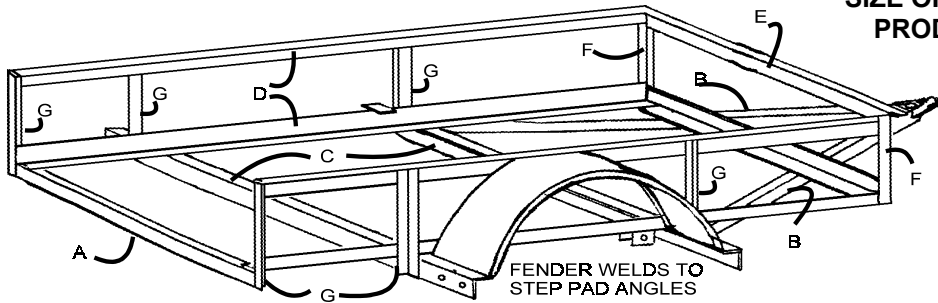

COUPLER DETERMINES TONGUE ANGLE

BUILD YOUR OWN TRAILER WITH OUR PARTS KIT (NO FRAME, YOU SUPPLY STEEL FRAME)

TANDEM AXLE TRAILER PARTS KIT (NO FRAME)

- KIT INCLUDES:**
 2 - 3500# PAINTED IDLER AXLES WITH HUBS
 4 - DOUBLE EYE SPRINGS
 2 - U-BOLT KITS
 1 - TANDEM SPRING HANGER KIT (PART # 4084)
 2 - EQUALIZERS (PART # 0454)
 1 - 2" A-FRAME COUPLER
 1 - 2000# A-FRAME JACK
 1 - LIGHT WIRING KIT
 2 - UNPAINTED 15" TANDEM FENDERS

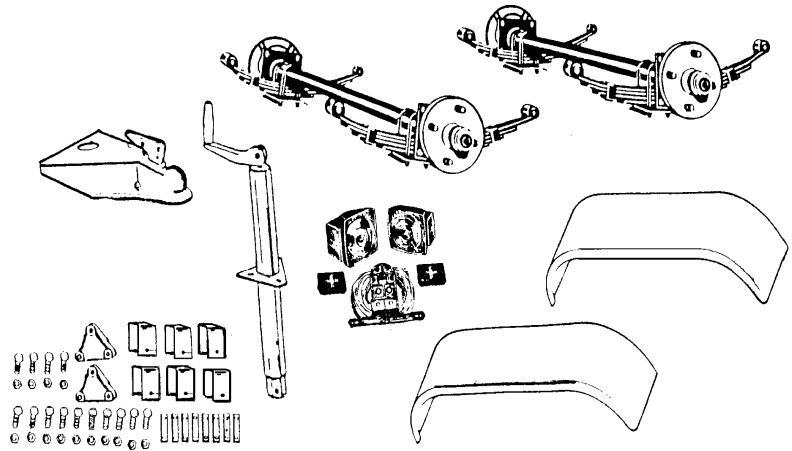

PART #	TRACK	HUB BOLT PATTERN	WT	KIT PRICE
4070	89"	5 ON 4.5" FORD	278#	\$329.95
4369	89"	5 ON 5" CHEVY	278#	\$329.95
4065	95"	5 ON 4.5" FORD	288#	\$341.95
4066	95"	5 ON 5" CHEVY	288#	\$341.95

BASIC TRAILER DESIGN FOR 7000# TANDEM TRAILER - BED SIZE 6' 4" X 16' USING 89" TRACK AXLE

# OF PIECES	ITEM #	SIZE	LENGTH	LOCATION
1	A	2 X 3" OR 3 X 4" ANGLE	84"	REAR CROSS MEMBER
3	B	2 X 3" ANGLE	76"	MIDDLE & FRONT BOTTOM CROSS MEMBERS
2	C	3 X 4" ANGLE	81"	TONGUE
2	D	2 X 3" ANGLE	93"	FENDER STEP CROSS MEMBERS
2	E	2 X 3" OR 3 X 4" ANGLE	192"	BOTTOM MAIN FRAMES
4	F	2 X 3" ANGLE	15" (OR LONGER)	FRONT & REAR VERTICAL SUPPORTS
6	G	2 X 3" ANGLE	18" (OR LONGER)	FENDER STEP VERTICAL SUPPORTS
1	H	2 X 3" ANGLE	80"	TOP FRONT CROSS RAIL
2	I	2 X 3" ANGLE	192"	TOP SIDE RAILS

PART # 4078 - TO ADD ELECTRIC BRAKES - ADD \$123.00 PER AXLE TO KIT PRICE
PART # 6119 - UPGRADE TO SPINDLE-LUBE AXLE - \$20.00 /PER AXLE

TANDEM AXLE LAYOUT WITH 25 1/4" DE SPRINGS AND EQUALIZER #0454 (7 1/2" X 3")

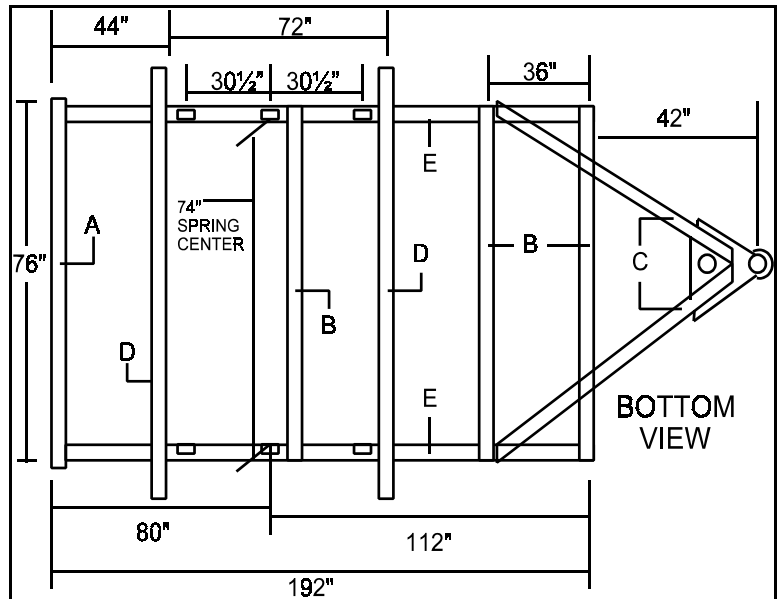
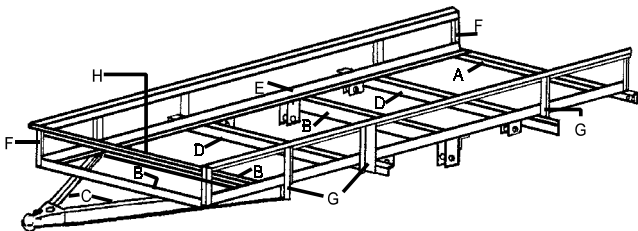
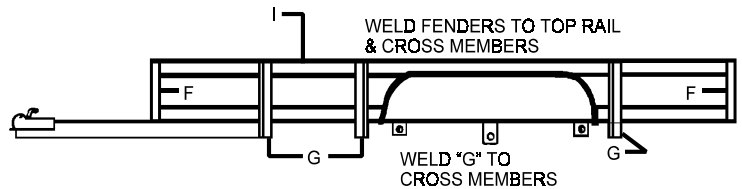
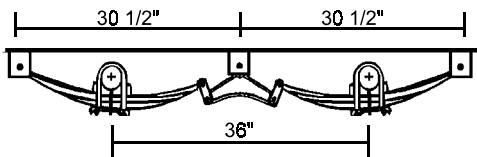

IF YOU WISH TO CHANGE THE LENGTH OF YOUR TRAILER BED, CALCULATE THE AXLE CENTER OF GRAVITY POINT BASED ON 60% IN FRONT OF (COG) AND 40% TO THE REAR OF (COG). EXAMPLE: SINGLE AXLE TRAILER WITH A 10' LONG BED WOULD HAVE THE CENTER OF THE AXLE 6' FROM THE FRONT AND 4' FROM THE REAR OF THE BED.

UTILITY TRAILER AXLES

PART #	AXLE SIZE	HUB BOLT PATTERN	WT	PRICE PER KIT	SINGLE AXLE UNDERCARRIAGE KIT INCLUDES: PAINTED UTILITY TRAILER AXLE SPRINGS, IDLER HUBS, HANGER KIT AND U-BOLT KIT
4076	73"	5 ON 4.5 - FORD	99#	\$132.95	
4371	73"	5 ON 5 - CHEVY	99#	\$132.95	
4111	89"	5 ON 4.5 - FORD	109#	\$133.95	
4370	89"	5 ON 5 - CHEVY	109#	\$133.95	
4064	95"	5 ON 4.5 - FORD	119#	\$145.95	
4067	95"	5 ON 5 - CHEVY	119#	\$145.95	

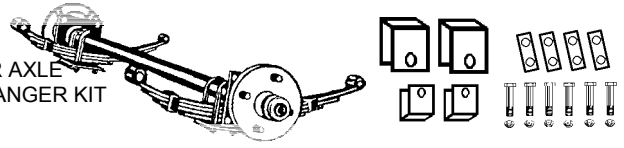

TANDEM AXLE UNDERCARRIAGE
 KIT INCLUDES:
 2 - 3500# PAINTED UTILITY TRAILER AXLES
 4 - SPRINGS
 4 - IDLER HUBS
 U-BOLT KIT, AND TANDEM SPRING HANGER KIT

4077	89"	5 ON 4.5 - FORD	218#	\$249.95
4372	89"	5 ON 5 - CHEVY	218#	\$249.95
4062	95"	5 ON 4.5 - FORD	228#	\$261.95
4063	95"	5 ON 5 - CHEVY	228#	\$261.95

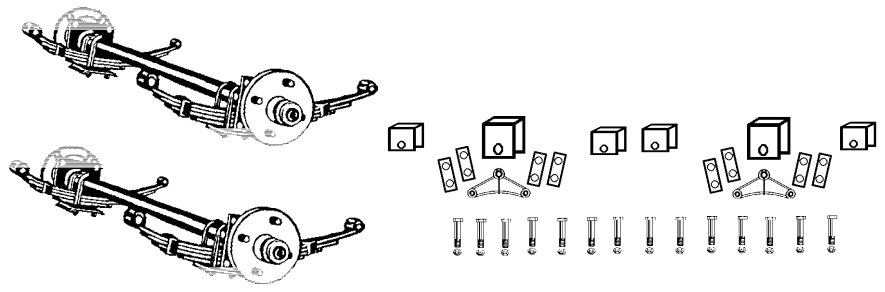

PART # 6119	UPGRADE YOUR UTILITY TRAILER AXLE TO HAVE SPINDLE LUBE SPINDLES	\$20.00 PER AXLE
PART # 4078	UPGRADE YOUR UTILITY TRAILER AXLE TO HAVE ELECTRIC BRAKES (3500# ONLY)	\$129.00 PER AXLE

3500# AND 6000# PAINTED STRAIGHT UTILITY TRAILER AXLES

CAN BE INSTALLED OVER OR UNDER THE SPRINGS
 (NO HUBS) ORDER HUBS SEPARATELY

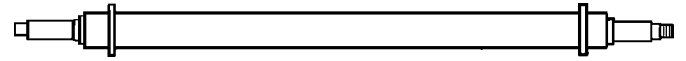

PART #	CAPACITY	AXLE DIAMETER	AXLE TRACK	SPRING PAD CENTER	TRAILER FRAME WIDTH	WT	PRICE EACH
4356	3500#	2 3/8" ROUND	73"	SHIP LOOSE	60"	48#	\$59.95
4357	3500#	2 3/8" ROUND	89"	SHIP LOOSE	76"	50#	\$59.95
4061	3500#	2 3/8" ROUND	95"	SHIP LOOSE	81"	55#	\$61.95
6118	6000#	3" ROUND	89"	SHIP LOOSE	76"	64#	\$98.62

**THESE AXLES ARE ONLY AVAILABLE IN THESE LENGTHS.
 FOR AXLES MANUFACTURED TO YOUR SPECIFICATIONS, SEE PAGES 2 & 3.**

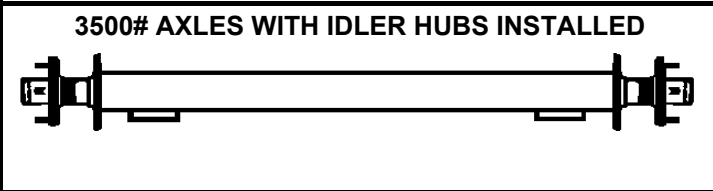

PART #	AXLE TRACK	SPRING CENTER	HUB BOLT PATTERN	WT	PRICE EA
4079	73"	SHIP LOOSE	5 ON 4.5 - FORD	61#	\$97.95
4358	73"	SHIP LOOSE	5 ON 5" - CHEVY	61#	\$97.95
5080	89"	SHIP LOOSE	5 ON 4.5" - FORD	63#	\$98.95
4359	89"	SHIP LOOSE	5 ON 5" - CHEVY	63#	\$98.95
0173	95"	SHIP LOOSE	5 ON 4.5 - FORD	68#	\$118.95
0174	95"	SHIP LOOSE	5 ON 5" - CHEVY	68#	\$118.95

UNPLATED TANDEM AXLE HANGER KIT FOR USE WITH DOUBLE EYE SPRINGS
 USE W/3500# OR 6000# AXLES

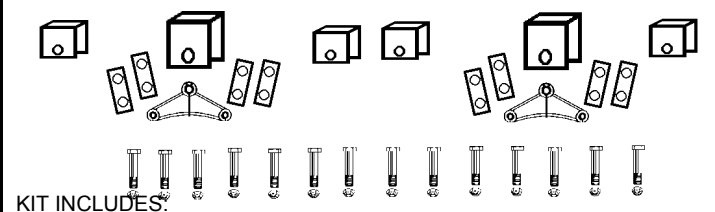

KIT INCLUDES:
 4 EA SHORT HANGERS
 2 EA EQUALIZERS (#0454)
 2 EA EQUALIZER HANGERS
 14 EA SPRING BOLTS (GRD 5)
 8 EA SHACKLE LINKS

PART # 4084
WT 24#
PRICE PER KIT \$32.95

UNPLATED SINGLE AXLE HANGER KIT FOR USE WITH DOUBLE EYE SPRINGS
 USE W/3500# OR 6000# AXLES

KIT INCLUDES:
 2 EA FRONT HANGERS
 2 EA REAR HANGERS
 4 SHACKLE LINKS
 6 SPRING BOLTS (GRD 5)

PART # 4083
WT 9#
PRICE PER KIT \$12.95

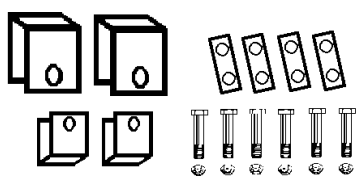

UNPLATED (BLACK IRON) ROUND AXLE U-BOLT KITS

PART #	AXLE SIZE	WT	KIT PRICE
6008	2 3/8" RND	8#	\$9.99
4507	3" RND	10#	\$11.99

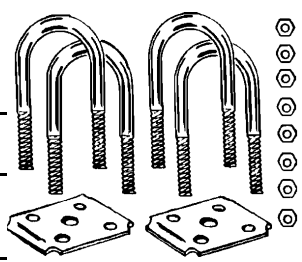

EZ LOADER® TRAILER PARTS

EZ LOADER® ROCKER ARM ASSEMBLIES

CUSTOMER MUST
SUPPLY PART # !!
SALES REP CAN NOT HELP
WITH EZ LOADER® PART #'S

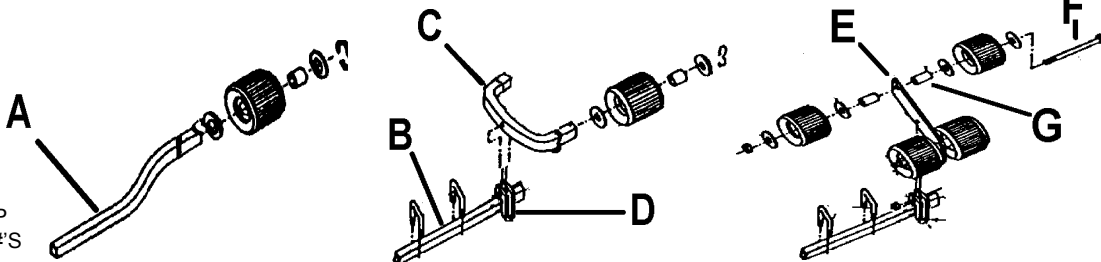

PART #	ITEM	EZ LOADER PART #	DESCRIPTION	WT	PRICE
3356	A	R10762A	15" SINGLE ARM	5#	\$10.88
3357	B	R15630A	15" QUAD ARM	6#	\$11.38
3358	C	R10431A	14 1/2" MULTI HEAD	5#	\$12.95
3359	D	R15629	MULTI ARM STRAP	.3#	\$6.49
3360	E	R1013A	10 3/4" FLAT BAR	3#	\$6.95
4239	F	F1697	5/8 X 8 BOLT WITH NUT	1#	\$3.69
3361	G	C1426	SPACER BUSHING	.1#	\$0.95

**GALVANIZED
ROCKER PLATE
FOR ROCKER ARM
ASSEMBLY**
PART #10794
WT 1#
PRICE \$6.95



**5" RIBBED ROLLER
WITH 2 EA 1 1/16" ID X 2" OD
STAINLESS STEEL WASHER
AND 1" ID BUSHING**

PART # 6017
WT 3#
PRICE \$9.95

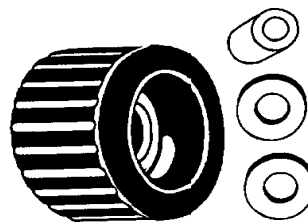

**C-HOOK EQUALIZER GALVANIZED 5/8"
CENTER BOLT HOLE AND 9/16" SPRING
BOLT HOLES**
PART # 3008
WT. 5.5#
PRICE \$29.95

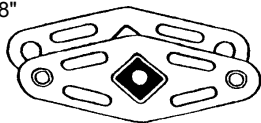

**1 1/16" ID X 2" OD
STAINLESS STEEL ROLLER WASHER**
PART # 6015
WT .2#
PRICE \$.89



**ALUMINUM GLIDE BEARING
FOR ROCKER ARM ASSEMBLY**
PART #1449
WT .3#
PRICE \$1.99 **ALUMINUM**



1" ID BUSHING FOR RIBBED ROLLER # 6017

PART # 1349
WT .2#
PRICE EA \$1.19

1" ID



**3/8 X 1 9/16 X 2" UBOLT
FOR ROCKER ARM ASSEMBLY**

PART #	TYPE	WT	PRICE
6016	STAINLESS STEEL	.3#	\$2.49



**5" RIBBED ROLLER WITH 3/4 ID
BUSHING AND 2 EA 5/8" ID
STAINLESS WASHERS**

REPLACES OLD STYLE EZ LOAD
ROLLERS W/2 PRESSED IN
13/16" ID X 2 1/2" OD WASHERS

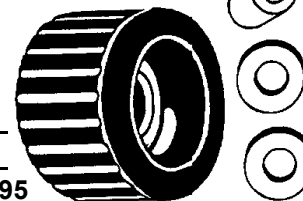

PART #	WASHER	WT	PRICE
2626	STAINLESS	3#	\$9.95

ZINC PLATED HOG RINGS
PART # 2650
WT .2#
PRICE \$.40 EA



**5/8" ID X 1 3/4" OD STAINLESS WASHER
FOR PART #2626 ROLLER
(2 REQUIRED PER ROLLER)**
PART #3311
WT .2#
PRICE \$.85

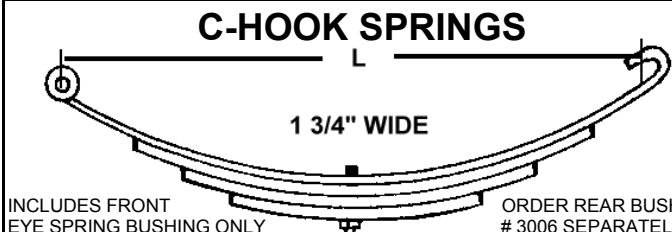

INCLUDES FRONT
EYE SPRING BUSHING ONLY

ORDER REAR BUSHING
3006 SEPARATELY

PART #	DESCRIPTION	LEAF THICK	CAP PER SPRING	WT	PRICE EACH
3012	3 LEAF 26" C-HOOK	.36	1750#	14#	\$18.99
0429	4 LEAF 26" C-HOOK	.36	2000#	18#	\$20.99
0430	5 LEAF 26" C-HOOK	.36	2500#	21#	\$22.99

**3/4" ID BUSHING FOR PART #2626
RIBBED ROLLER**
PART #3312
WT .2#
PRICE EA \$1.19

3/4" ID



3006	BUSHING FOR REAR OF SPRING 1" OD X 9/16" ID	.1#	\$1.30
------	---	-----	--------

PART #	DESCRIPTION	WT	PRICE
1310	13/16" ID X 2 1/2" OD ROLLER WASHER FOR USE WITH OLD STYLE ROLLER ONLY	.2#	\$1.29

